

IE2

CONTENTS

2 General specification

3 Performance data

5 Dimensions



DIMENSIONS MOUNT B5 and V1

Frame	pole	AC	AD	D	DH	E	ED	F	G	GD	KK	L	LA	M	N	P	S	T
80	2-8	160	145	19	M6X16	40	25	6	15.5	6	M24X15	280	12	165	130	200	4-φ12	4
90S	2-8	180	155	24	M8X19	50	40	8	20	7	M24X15	315	12	165	130	200	4-φ12	4
90L	2-8	180	155	24	M8X19	50	40	8	20	7	M24X15	340	12	165	130	200	4-φ12	4
100	2-8	200	180	28	M10X22	60	45	8	24	7	M24X15	375	13	215	180	250	4-φ15	4
112	2-8	220	193	28	M10X22	60	45	8	24	7	M30X2	400	14	215	180	250	4-φ15	4
132S	2-8	260	223	38	M12X28	80	63	10	33	8	M30X2	465	14	265	230	300	4-φ15	4
132M	2-8	260	223	38	M12X28	80	63	10	33	8	M30X2	505	14	265	230	300	4-φ15	4
160M	2-8	315	265	42	M16X36	110	90	12	37	8	M36X2	608	15	300	250	350	4-φ19	5
160L	2-8	315	265	42	M16X36	110	90	12	37	8	M36X2	652	15	300	250	350	4-φ19	5
180M	2-8	360	280	48	M16X36	110	90	14	42.5	9	M36X2	690	15	300	250	350	4-φ19	5
180L	2-8	360	280	48	M16X36	110	90	14	42.5	9	M36X2	730	15	300	250	350	4-φ19	5
200L	2-8	400	310	55	M20X42	110	90	16	49	10	M48X2	760	17	350	300	400	4-φ19	5
225S	4-8	450	330	60	M20X42	140	110	18	53	11	M48X2	810	20	400	350	450	4-φ19	5
225M	2	450	330	55	M20X42	110	110	16	49	10	M48X2	805	20	400	350	450	4-φ19	5
225M	4-8	450	330	60	M20X42	140	110	16	53	11	M48X2	835	20	400	350	450	4-φ19	5
250M	2	485	375	60	M20X42	140	110	18	53	11	M48X2	910	22	500	450	550	4-φ19	5
250M	4-8	485	375	65	M20X42	140	110	18	58	11	M48X2	910	22	500	450	550	4-φ19	5
280S	2	550	405	65	M20X42	140	110	18	58	11	M64X2	985	22	500	450	550	4-φ19	5
280S	4-8	550	405	75	M20X42	140	110	20	67.5	12	M64X2	1005	22	500	450	550	4-φ19	5
280M	2	550	405	65	M20X42	140	110	18	58	11	M64X2	1030	22	500	450	550	4-φ19	5
280M	4-8	550	405	75	M20X42	140	110	20	67.5	12	M64X2	1060	22	500	450	550	4-φ19	5

Note: * means that the cable gland is only one.

KK are also available according to the requirement.

Dimensions face-flange mount B14

IE2 56-132

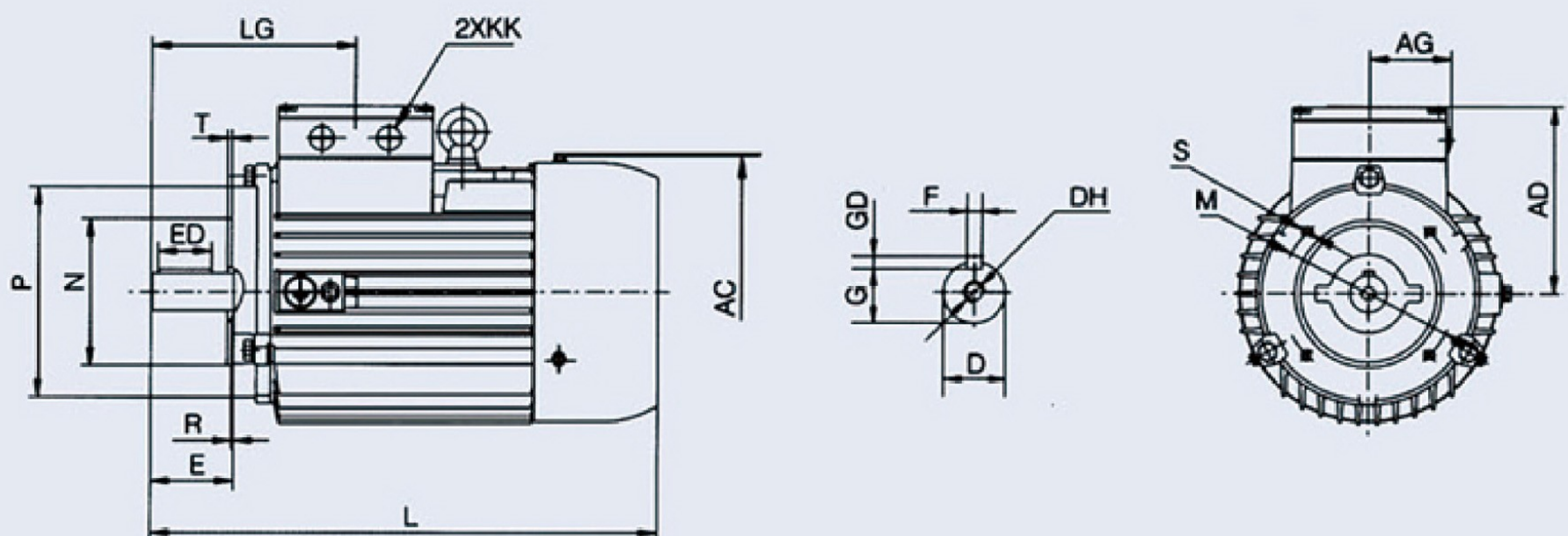

Frame	AC	AD	D	DH	E	ED	F	G	GD	KK	L	M	N	P	S	T
80	160	145	19	M6X16	40	25	6	15.5	6	M24X15	280	100	80	120	M6	3
90S	180	155	24	M8X19	50	40	8	20	7	M24X15	315	115	95	140	M8	3
90L	180	155	24	M8X19	50	40	8	20	7	M24X15	340	115	95	140	M8	3
100	200	180	28	M10X22	60	45	8	24	7	M24X15	375	130	110	160	M8	3.5
112	220	193	28	M10X22	60	45	8	24	7	M30X2	400	130	110	160	M8	3.5
132S	260	223	38	M12X28	80	63	10	33	8	M30X2	465	165	130	200	M10	4
132M	260	223	38	M12X28	80	63	10	33	8	M30X2	505	165	130	200	M10	4

- All motors comply with the requirements for European CE Marking.
- Energy-saving motors according to CEMEP.
- The insulation system is class F (105K) and the motors are designed to operate with class B (80K) (F級絕緣、B級溫昇)
- The degree of protection is IP55. (防護等級 IP55)
- Service Factor is 1.15 (安全係數1.15)
- The cooling method is Totally Enclosed Fan Cooled(TEFC).
- Standard voltages
IEC 80-225
220V, 230V, 240V / 380V, 415V, 440V, 460V
50Hz / 60Hz
IEC 250-355
200-660V at a frequency 50 or 60 Hz
- Stringent quality procedures are observed from first design to finished products in accordance with ISO9001 documented quality systems.

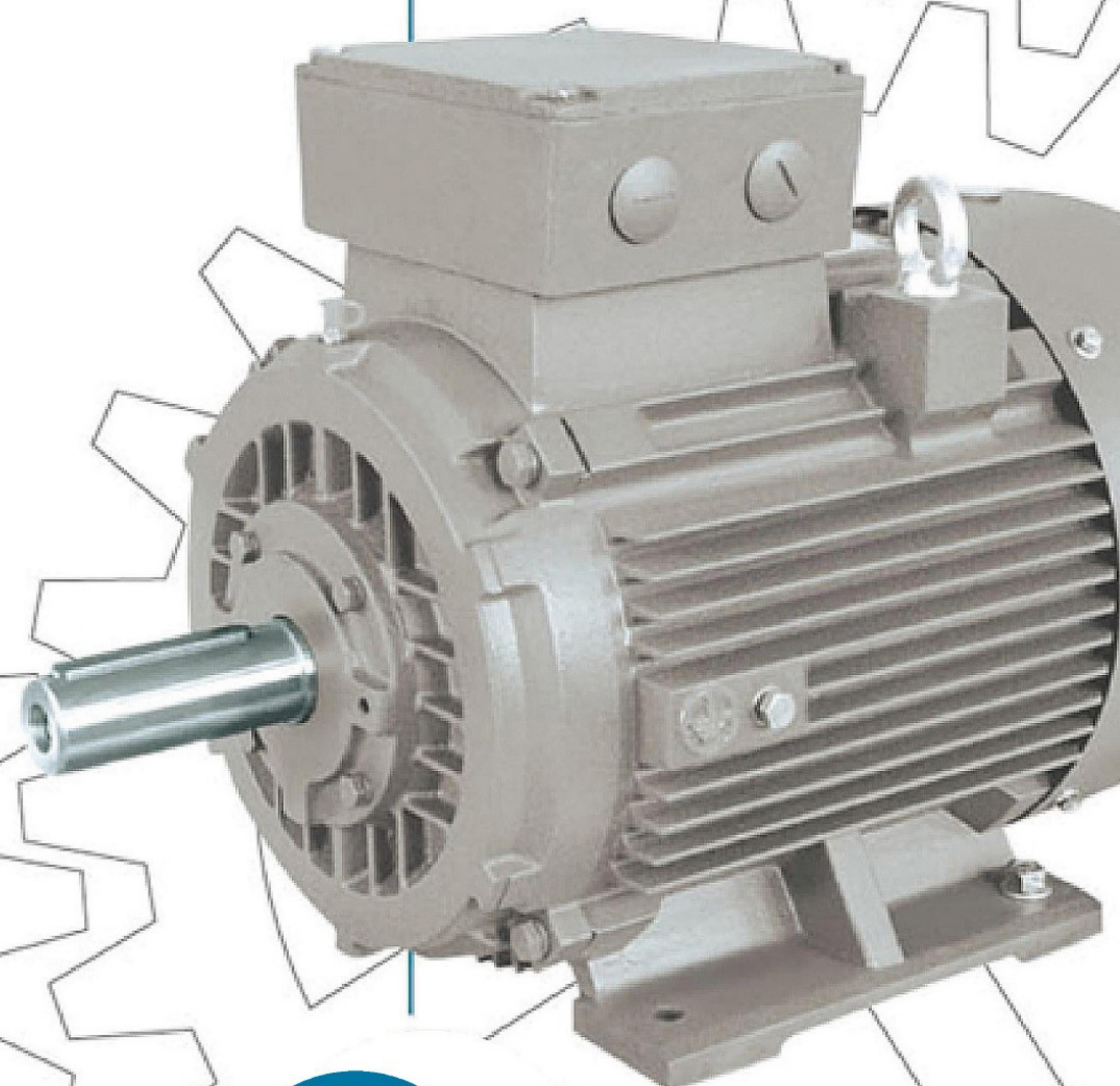
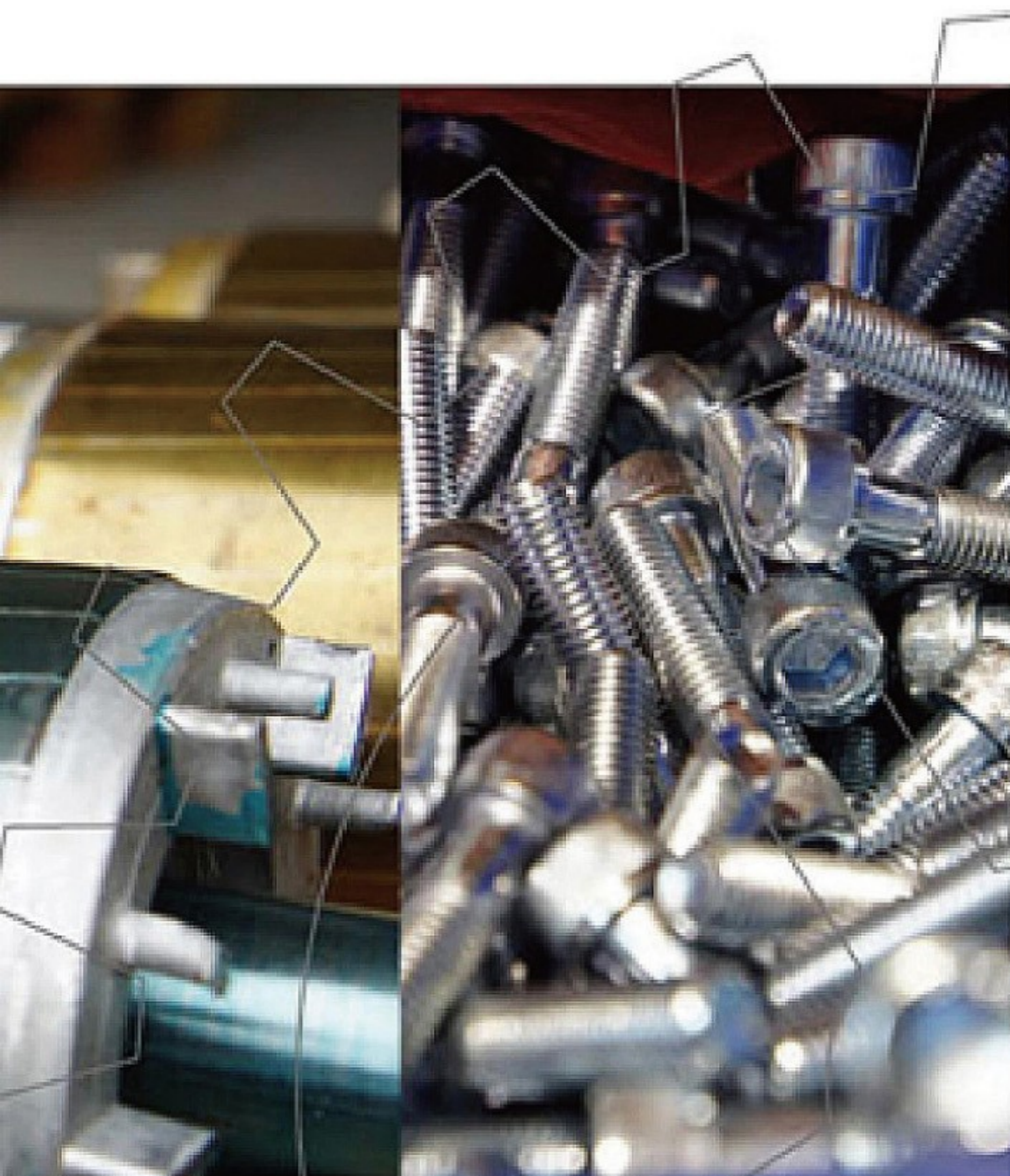

General specification

Introduction

IE2 motors are suitable for driving various kinds of machine or equipment. The output ratings are from 0.06kw to 355kw. The frame sizes are from 80 to 355.

All motors comply with the requirements for European CE marking.

All motors are designed for high efficiency and low temperature rise giving a long economical service life.

- Motors with terminal boxes on the right side or on the left side are available.
- Motors from frame sizes 80 to 160 with cast iron stator frames, terminal boxes and cast iron endshields are standard.

Specification

Site conditions

IE2 motors are suitable for almost all applications and will operate satisfactorily at temperatures from -20°C to +40°C and at altitudes up to 1000 meters above sea level.

Insulation and temperature rise (F級絶縁、B級温昇)

The insulation system is Class F (105K) and the motors are designed to operate with Class B (80K).

This ensures long life and reliability with the ability to withstand ambient temperatures as high as 54°C or up to 15% overload in adverse electrical supply situations.

Cooling and ventilation

The standard cooling method is totally Enclosed Fan Cooled (TEFC) in accordance with code IC411 of IEC 60034-6.

Standard motors in sizes 56-315 are equipped with radial flow plastic fans.

Standard motors in size 355 are equipped with radial flow aluminium fans.

Enclosure (防護等級 IP55)

The standard degrees of protection is IP55.

The IP55 enclosure means complete hoseproof and dustproof protection.

A higher degrees of protection is available.

Motor protection

Motors can be protected by PTC thermistors in the stator winding (1 or 2 sets of PTC thermistors).

Other kinds of protection are available on request.

Voltage and frequency

IEC 56-225

- 220V, 230V, 240V / 380V, 415V, 440V, 460V
50Hz / 60Hz

IEC 250-355

- 200-660V at a frequency 50 or 60 Hz

The motors will operate satisfactorily with voltage variations of $\pm 10\%$ from the rated voltage.

Connecton

Direct-on-line starting can be used on all frame sizes. Motors up to and including 2.2kW are star connected and cannot be started with Star/Delta starter. Motors above 2.2kW are delta connected with 6 terminals for Star/Delta starting.

Noise

The permitted noise levels of electrical machines are fixed in IEC60034-9 (EN60034-9). The noise level of IE2 motors is well below this limit values.

For detail, please refer to the performance data tables.

Vibration

Standard motors are designed to vibration class N (normal), vibration class R (reduced) and vibration class S (special) are available on request.

Quality assurance

Stringent quality procedures are observed from first design to finished products in accordance with ISO9001 documented quality systems.

Our factories have been assessed to meet these requirements, a further assurance that only the highest possible standards of quality are accepted.

IE2

2 Pole-3600 rpm synchronous speed 60Hz

Motor Type	Rated Power (KW/HP)	Rated Current 380V	Rated Speed (r/min)	Power Factor cos ϕ	EFF	IST/ IFL	TST/ TFL	TM/TFL	M of I kgm'	Net weight (kg)
MA-80I2	0.75 / 1.00	1.8	3400	0.83	75.5	7.1	1.9	2.1	0.00094	16
MA-90S2	1.50 / 2.00	3.2	3420	0.84	84.0	6.8	2.3	2.9	0.0016	22
MA-90L2	2.20 / 3.00	4.6	3430	0.85	85.5	7.0	2.3	2.9	0.0020	25
MA-112M2	4.00 / 5.50	7.8	3455	0.88	87.5	7.6	1.8	3.1	0.0064	40
MA-132S12	5.50 / 7.50	10.7	3500	0.88	88.5	7.5	2.0	3.2	0.0152	59
MA-132S22	7.50 / 10.0	14.2	3500	0.89	89.5	7.8	2.2	3.2	0.0160	62
MA-160M12	11 / 15	20.8	3520	0.89	90.2	7.8	2.0	2.8	0.0486	107
MA-160M22	15 / 20	28.4	3520	0.89	90.2	7.0	1.8	2.4	0.0604	117
MA-160L2	18.5 / 25	34.6	3520	0.89	91.0	7.1	1.8	2.3	0.0719	134
MA-180M2	22 / 30	41.2	3540	0.89	91.0	7.6	1.6	3.0	0.1051	169
MA-200L12	30 / 40	55.8	3546	0.89	91.7	7.5	1.7	3.1	0.1233	185
MA-200L22	37 / 50	68.3	3564	0.89	92.4	7.3	1.7	2.6	0.1903	239
MA-225M2	45 / 60	82.6	3564	0.89	93.0	7.4	1.7	2.6	0.2156	254
MA-250M12	55 / 75	100.9	3564	0.89	93.0	7.6	2.2	3.0	0.3135	315
MA-280S2	75 / 100	136.7	3570	0.89	93.6	8.1	2.3	2.9	0.4675	425
MA-280M12	90 / 125	162.6	3570	0.89	94.5	7.6	2.1	2.7	0.5885	450
MA-315S2	110 / 150	196.4	3570	0.90	94.5	7.9	1.7	2.9	0.9515	540
MA-315M2	132 / 180	234.6	3575	0.90	95.0	7.6	1.6	2.8	1.0472	570
MA-315L12	160 / 220	280.0	3575	0.91	95.4	7.1	1.6	2.5	2.1351	1080
MA-315L22	200 / 270	350.0	3575	0.91	95.4	7.3	1.7	2.6	2.4332	1170

Frame size of motor	Poles	Drive End	Non-Drive End	Frame size of motor	Poles	Drive End	Non-Drive End
63	All	6201ZZ/C3	6201ZZ/C3	200	4,6,8	6312/C3	6212/C3
71	All	6202ZZ/C3	6202ZZ/C3	225	2	6312/C3	6312/C3
80	All	6204ZZ/C3	6204ZZ/C3	225	4,6,8	6313/C3	6312/C3
90	All	6205ZZ/C3	6204ZZ/C3	250	2	6313/C3	6313/C3
100	All	6206ZZ/C3	6206ZZ/C3	250	4,6,8	6314/C3	6313/C3
112	All	6306ZZ/C3	6306ZZ/C3	280	2	6314/C3	6314/C3
132	All	6308ZZ/C3	6308ZZ/C3	280	4,6,8	6317/C3	6314/C3
160	All	6309ZZ/C3	6309ZZ/C3	315	2	6317/C3	6317/C3
180	2	6211/C3	6211/C3	315	4,6,8	NU319/C3	6317/C3
180	4,6,8	6311/C3	6211/C3	355	2	6319/C3	6319/C3
200	2	6212/C3	6212/C3	355	4,6,8	NU322/C3	6319/C3

所使用之軸承為SKF或NSK，其為高精密等級低磨擦型系列
160框以下為自潤式軸承設計，180框以上為注油式軸承設計

IE2 series

4 Pole-1800 rpm synchronous speed 60Hz

Motor Type	Rated Power (KW/HP)	Rated Current 380V	Rated Speed (r/min)	Power Factor cos ϕ	EFF	IST/ IFL	TST/ TFL	TM/TFL	M of I kgm'	Net weight (kg)
MA-8024	0.75 / 1.00	1.8	1690	0.75	82.5	6.2	2.2	2.8	0.0017	18
MA-90L4	1.50 / 2.00	3.6	1700	0.75	84.0	6.5	1.8	2.8	0.0032	28
MA-100L14	2.20 / 3.00	4.8	1730	0.79	87.5	6.6	2.0	2.9	0.0067	34
MA-112M4	4.00 / 5.50	8.6	1730	0.80	87.5	7.7	2.1	3.1	0.0129	44
MA-132S4	5.50 / 7.50	11.3	1740	0.82	89.5	7.8	2.0	2.6	0.0271	61
MA-132M4	7.50 / 10.0	15.3	1740	0.83	89.5	7.8	2.1	2.3	0.0363	73
MA-160M4	11 / 15	21.9	1760	0.84	91.0	7.1	1.6	2.1	0.0889	113
MA-160L4	15 / 20	29.4	1750	0.85	91.0	7.4	2.0	2.2	0.1157	133
MA-180M4	18.5 / 25	35.3	1752	0.86	92.4	7.2	1.6	3.1	0.1649	167
MA-180L4	22 / 30	42.0	1764	0.86	92.4	7.6	1.6	3.2	0.1825	181
MA-200L4	30 / 40	56.9	1764	0.86	93.0	7.5	1.6	3.1	0.2103	195
MA-225S4	37 / 50	70.2	1770	0.86	93.0	7.5	1.9	2.8	0.3256	255
MA-225M4	45 / 60	84.9	1776	0.86	93.6	7.3	1.8	2.7	0.3575	278
MA-250M14	55 / 75	103.2	1776	0.86	94.1	7.4	2.1	3.0	0.8415	335
MA-280S4	75 / 100	138.5	1782	0.87	94.5	7.5	1.9	2.6	0.9372	425
MA-280M14	90 / 125	166.3	1782	0.87	94.5	7.5	1.7	2.4	1.0296	450
MA-315S4	110 / 150	199.9	1783	0.88	95.0	6.9	1.8	2.9	2.3353	600
MA-315M4	132 / 180	239.9	1785	0.88	95.0	7.1	1.9	3.0	2.7852	650
MA-315L14	160 / 220	286.2	1785	0.89	95.4	6.6	1.6	2.6	4.9192	1070
MA-315L24	200 / 270	357.8	1785	0.89	95.4	7.0	1.7	2.7	5.3416	1181

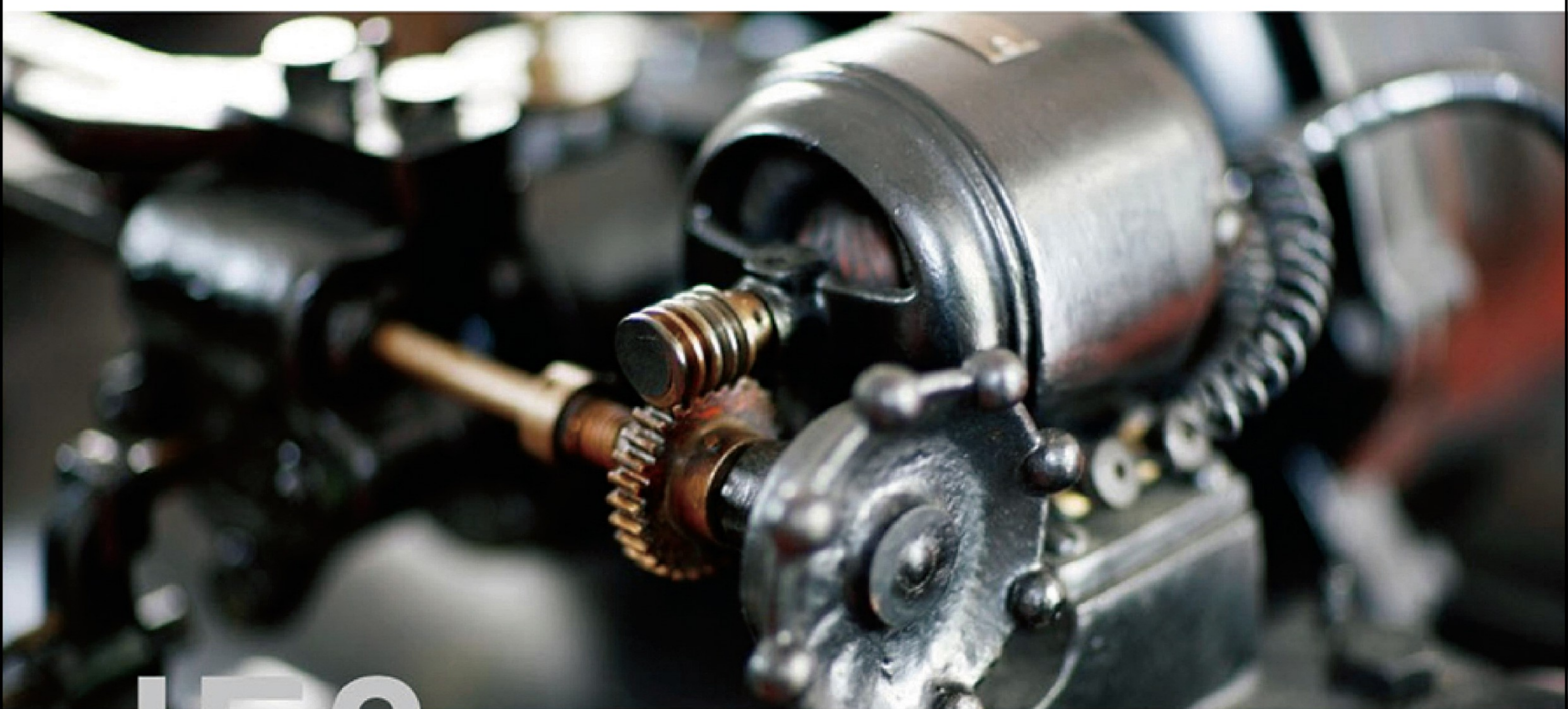

IE2

6 Pole-1200 rpm synchronous speed 60Hz

Motor Type	Rated Power (KW/HP)	Rated Current 380V	Rated Speed (r/min)	Power Factor cos ϕ	EFF	IST/ IFL	TST/ TFL	TM/TFL	M of I kgm'	Net weight (kg)
MA-90S6	0.75 / 1.00	1.9	1110	0.72	80.0	5.0	2.0	2.5	0.0032	23
MA-100L6	1.50 / 2.00	3.5	1130	0.74	86.5	5.9	2.1	2.6	0.0082	33
MA-112M6	2.20 / 3.00	5.1	1140	0.74	87.5	6.6	1.7	2.4	0.0146	39
MA-132M16	4.00 / 5.50	9.3	1150	0.74	87.5	6.7	1.9	2.6	0.0409	56
MA-132M26	5.50 / 7.50	12.4	1160	0.75	89.5	6.8	1.8	2.4	0.0538	71
MA-160M6	7.50 / 10.0	16.3	1160	0.78	89.5	6.1	1.5	2.7	0.0965	108
MA-160L6	11 / 15	23.8	1160	0.78	90.2	6.3	1.5	2.6	0.1333	131
MA-180L6	15 / 20	31.2	1170	0.81	90.2	7.2	2.0	2.6	0.2295	171
MA-200L16	18.5 / 25	37.8	1176	0.81	91.7	6.8	1.8	2.4	0.2784	182
MA-200L26	22 / 30	44.4	1182	0.82	91.7	7.1	1.9	2.5	0.3313	195
MA-225M6	30 / 40	60.5	1188	0.81	93.0	6.6	1.8	2.5	0.3982	245
MA-250M6	37 / 50	71.9	1188	0.84	93.0	6.8	1.9	2.6	0.4246	275
MA-280S6	45 / 60	84.9	1188	0.86	93.6	7.2	1.7	2.3	0.9515	330
MA-280M16	55 / 75	103.8	1188	0.86	93.6	6.9	1.8	2.7	1.2485	408
MA-315S6	75 / 100	142.4	1185	0.85	94.1	6.8	1.6	2.3	1.5015	435
MA-315M6	90 / 125	173.1	1185	0.84	94.1	6.7	1.7	2.5	2.6015	620
MA-315L16	110 / 150	206.9	1185	0.85	95.0	6.9	1.8	2.6	3.2857	665
MA-315L26	132 / 180	245.4	1185	0.86	95.0	6.4	1.6	2.3	6.2535	1090
MA-355M16	160 / 210	294.1	1190	0.87	95.0	6.3	1.6	2.2	7.0972	1175

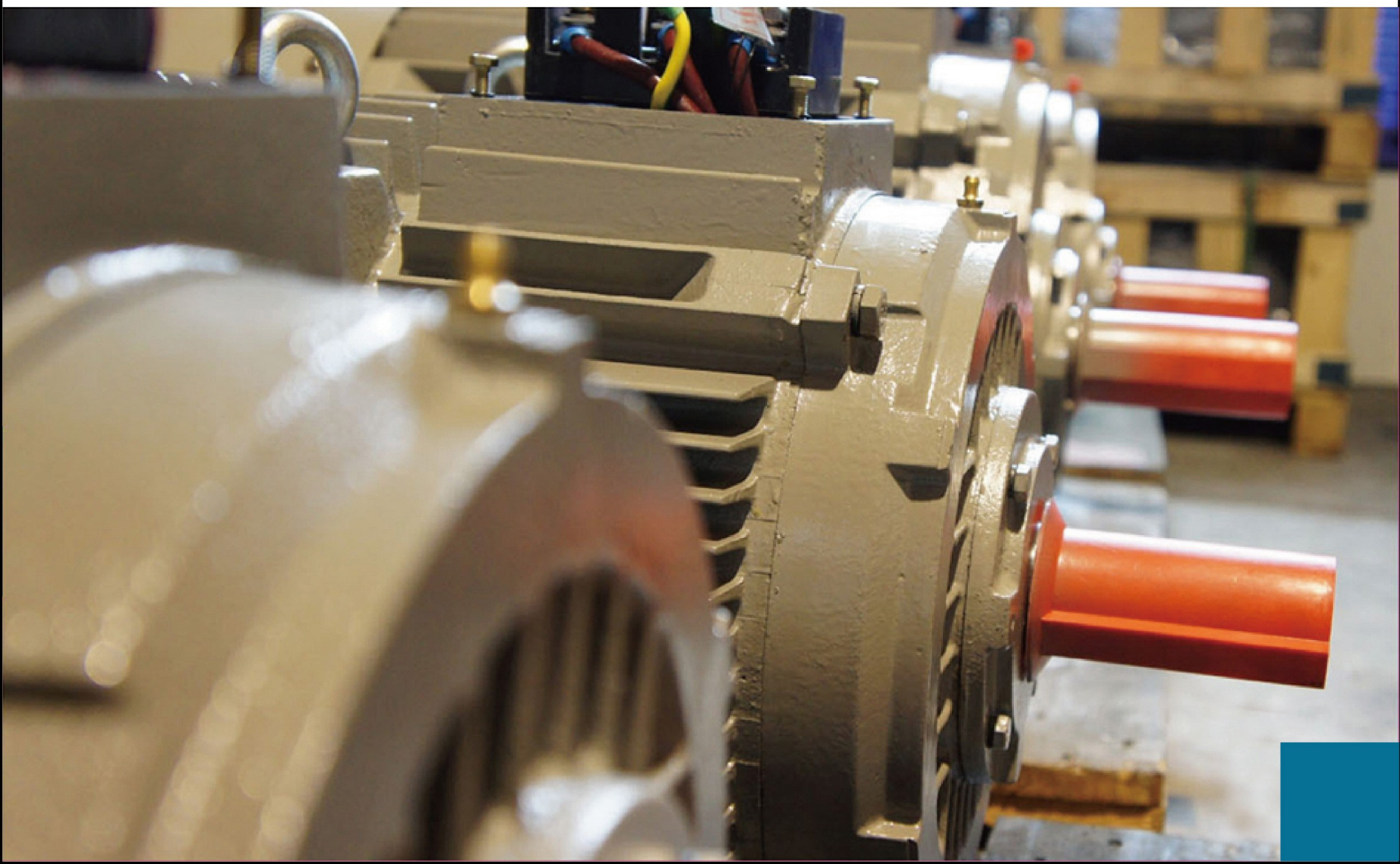

Dimensions foot mount B3

IE2-56-160

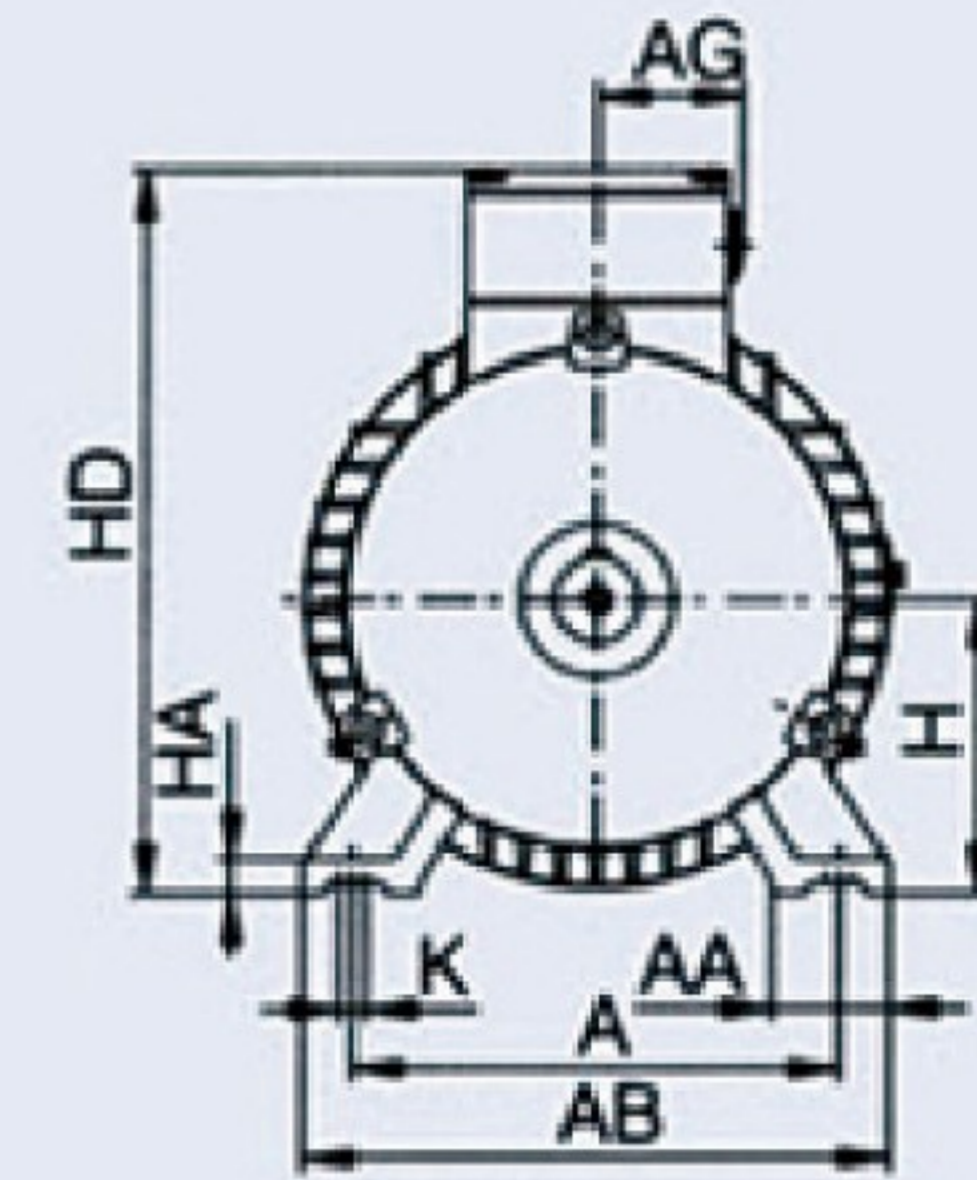
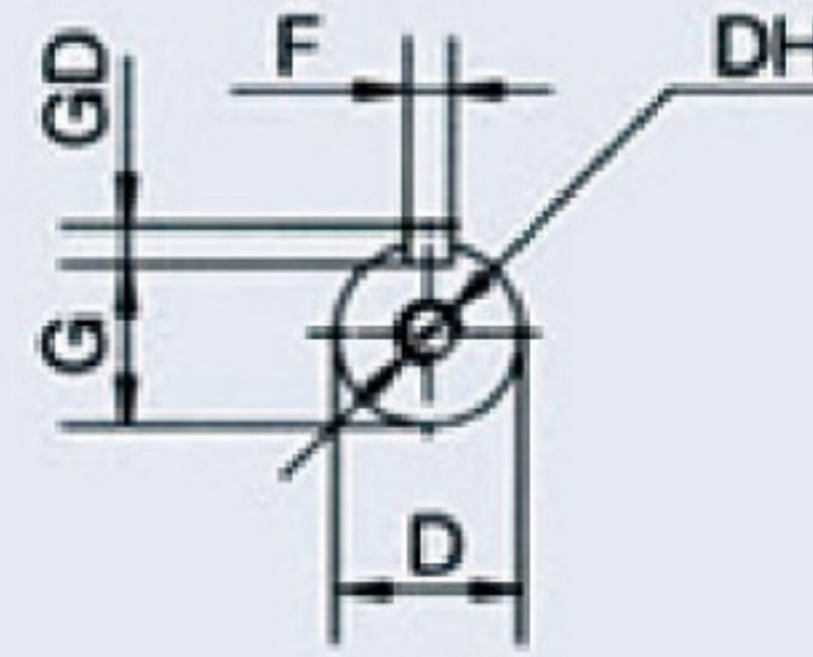
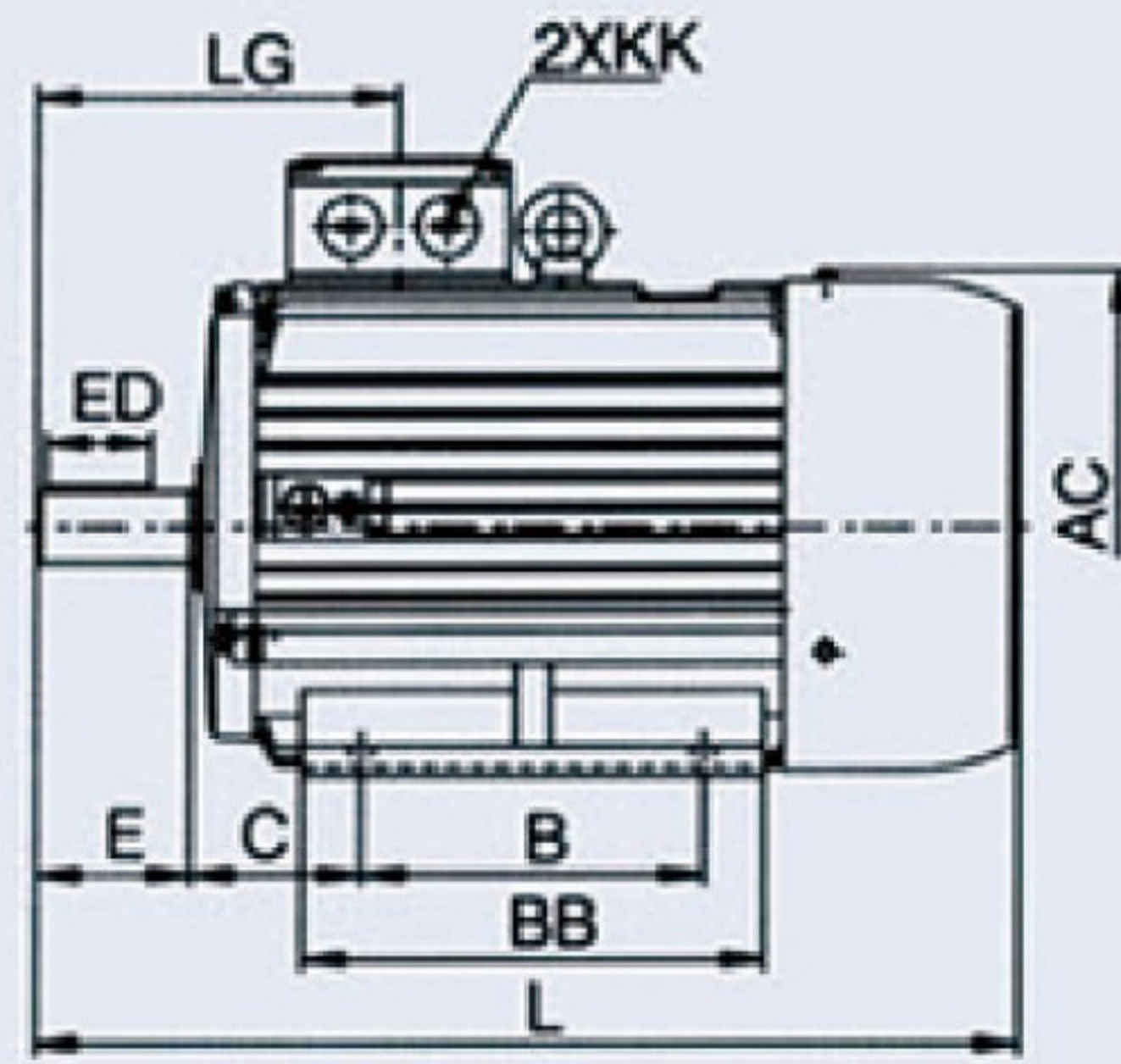

IE2-180-200

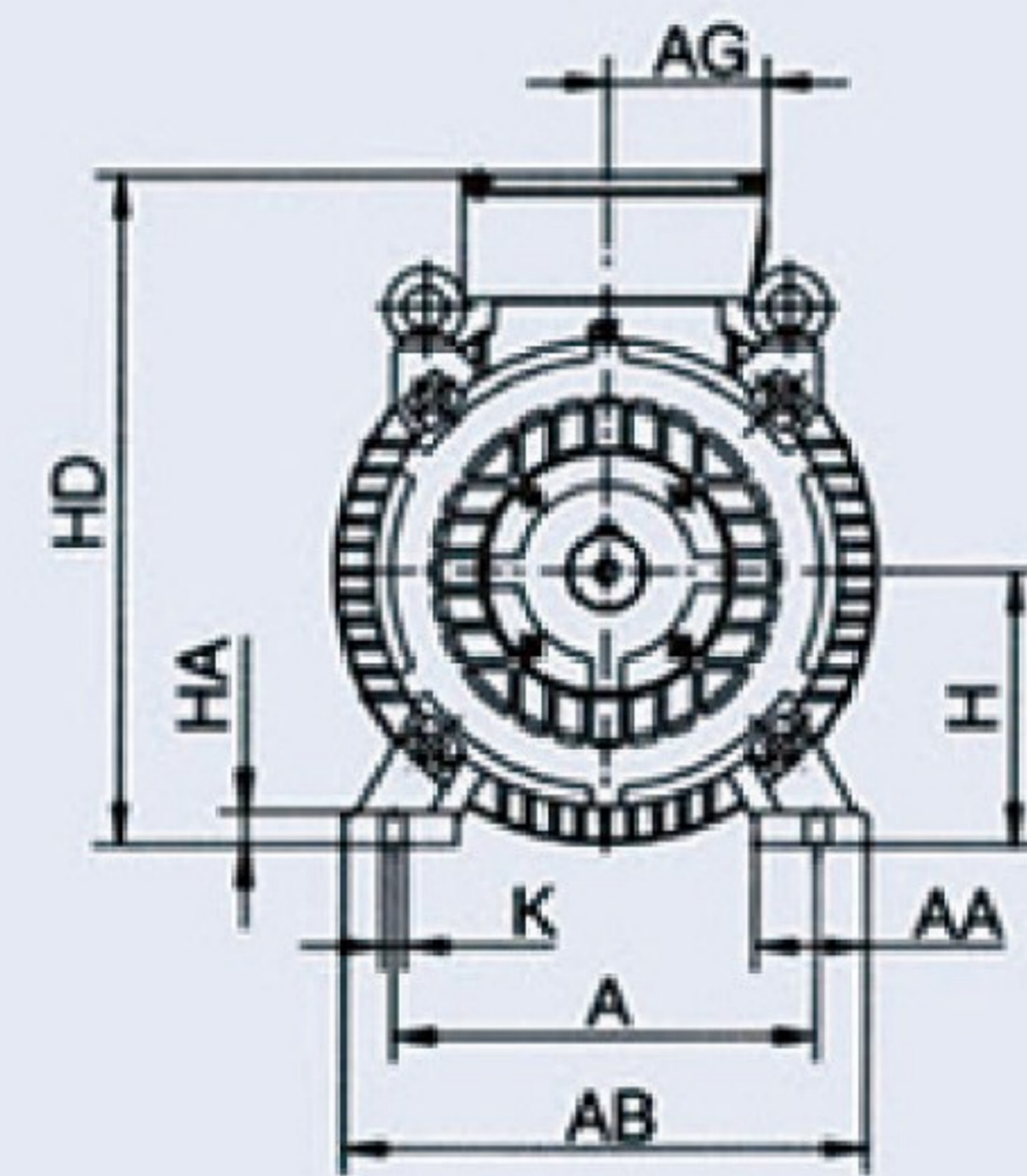
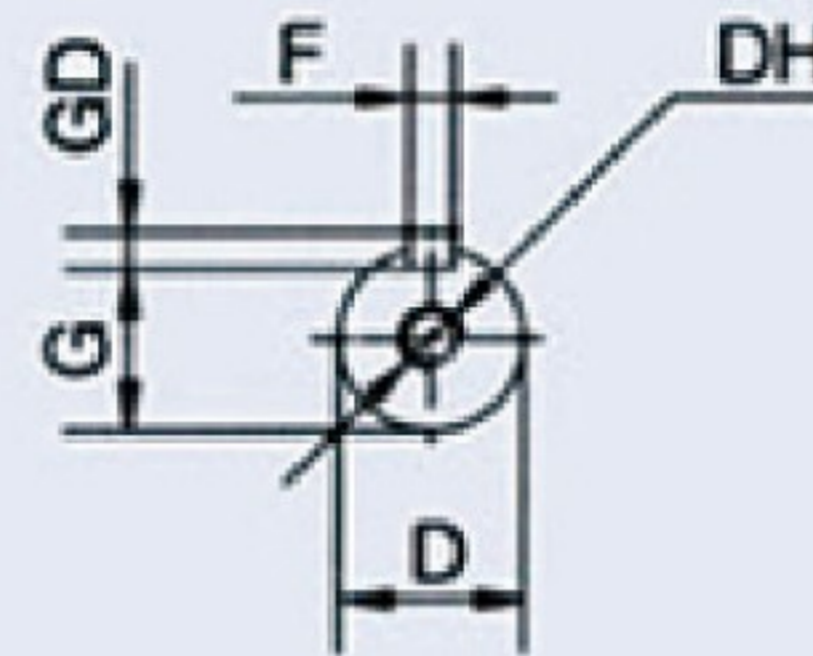
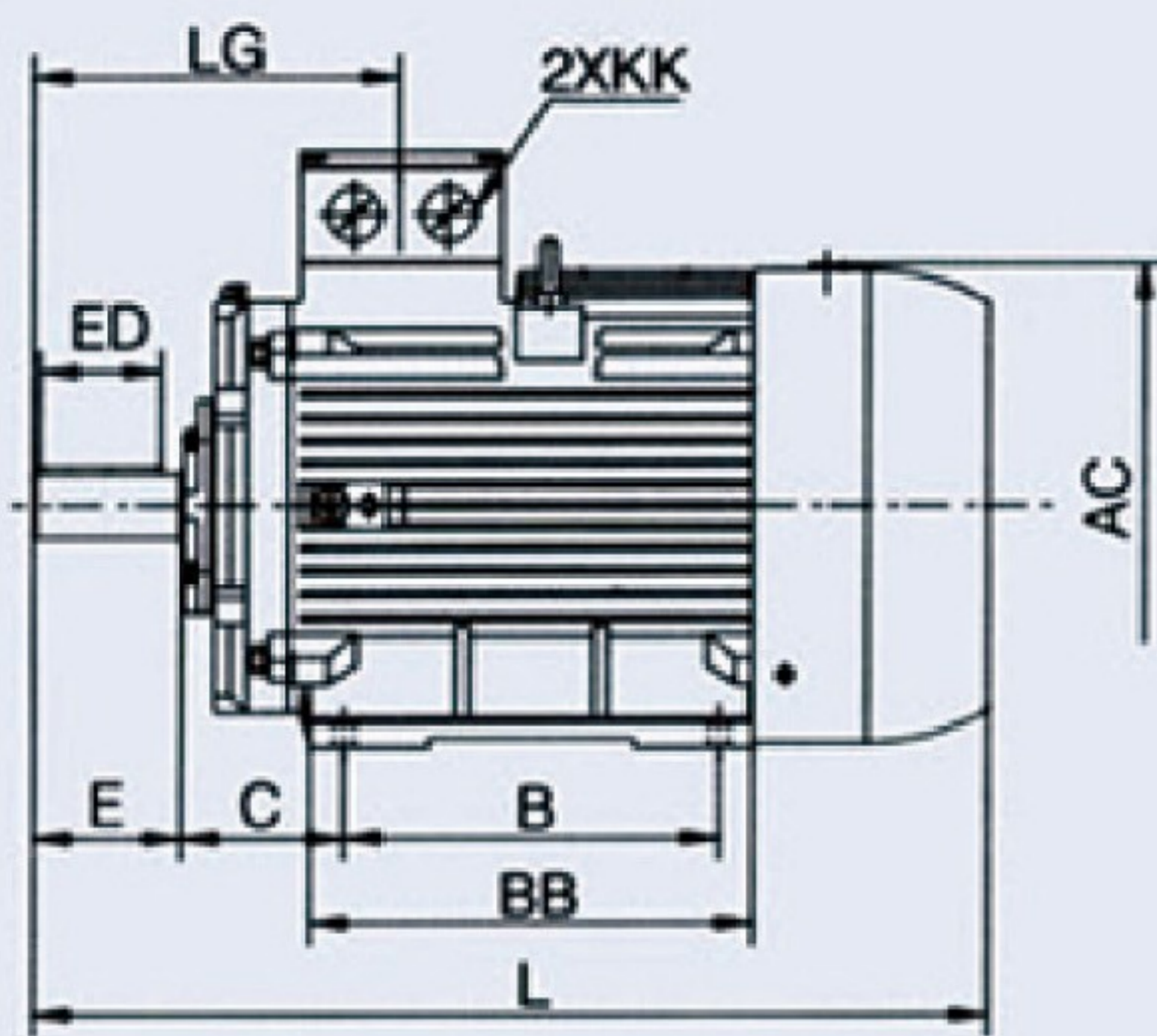

IE2-225-280

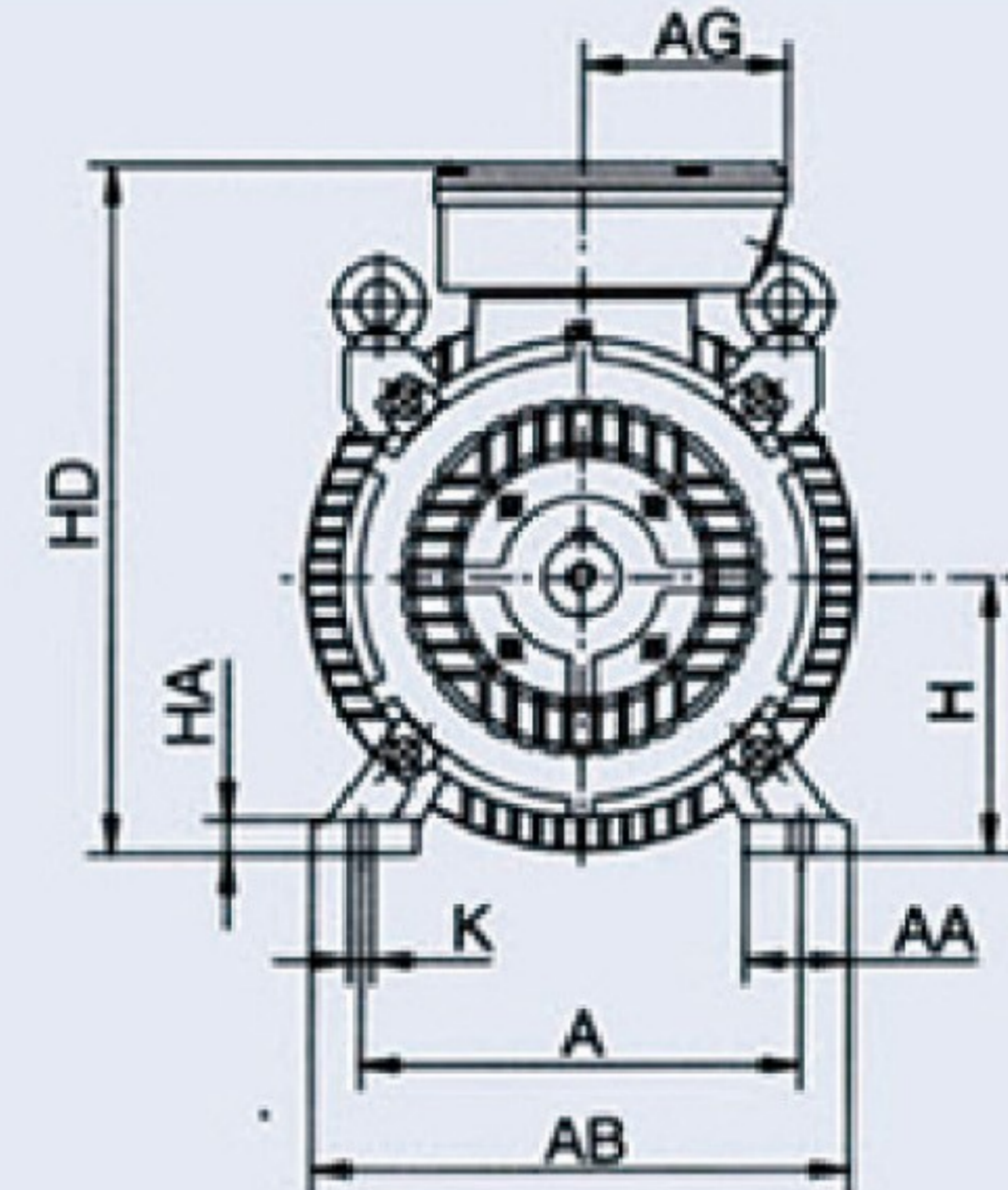
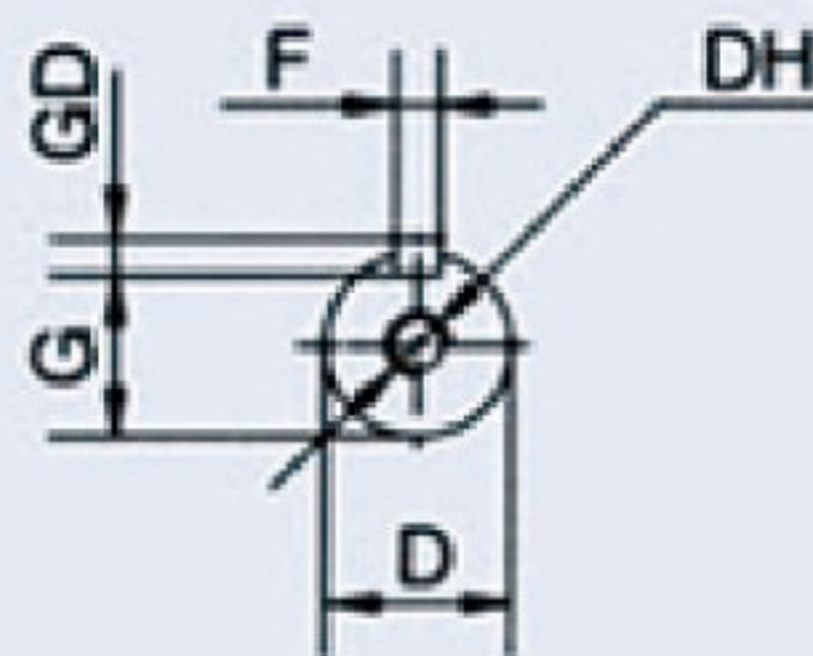
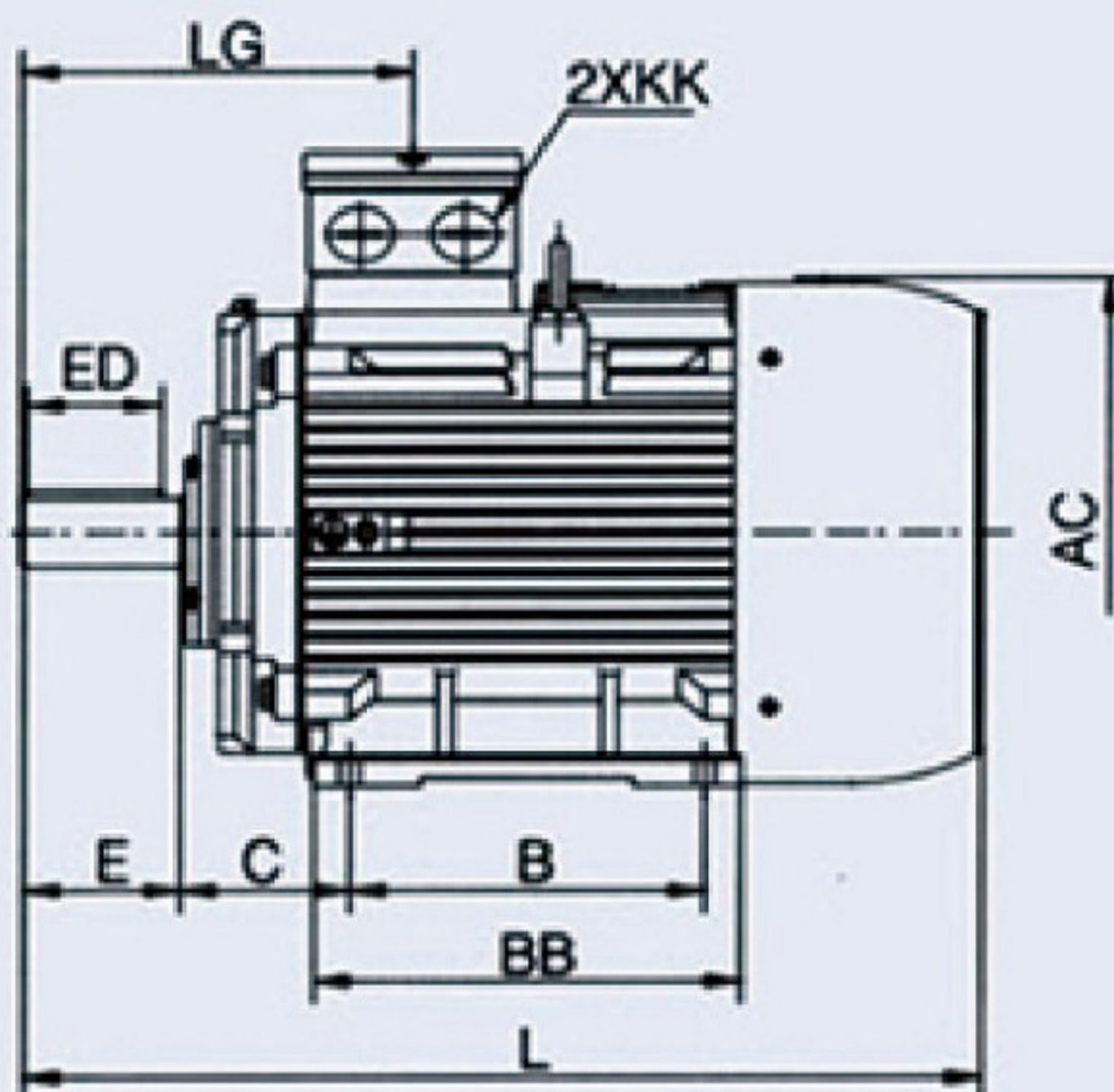

IE2-315-355

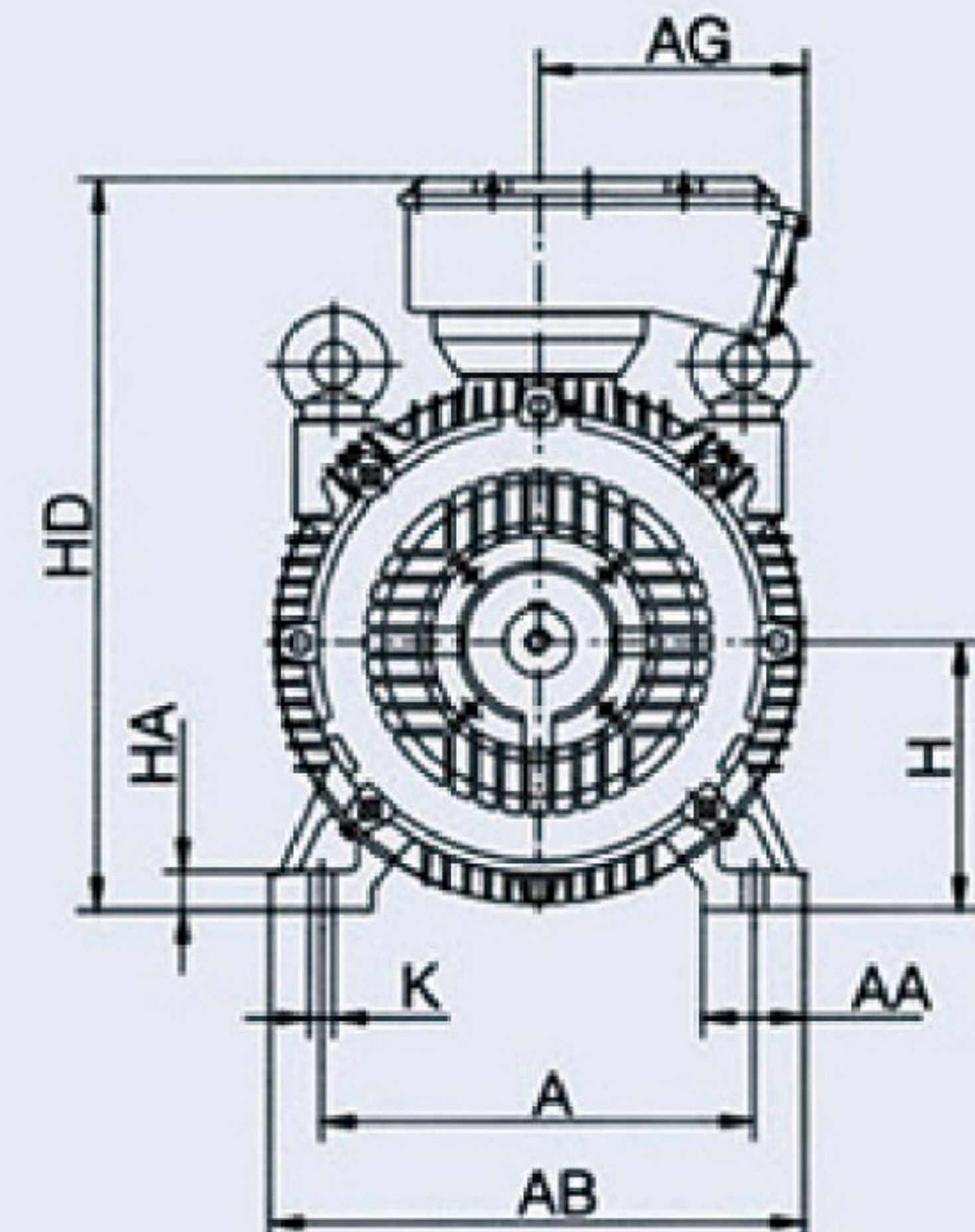
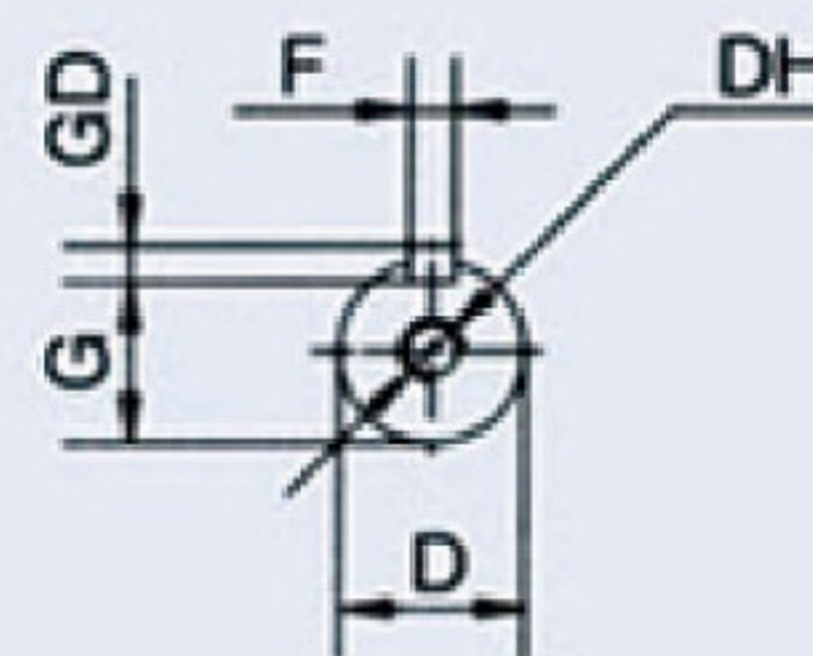
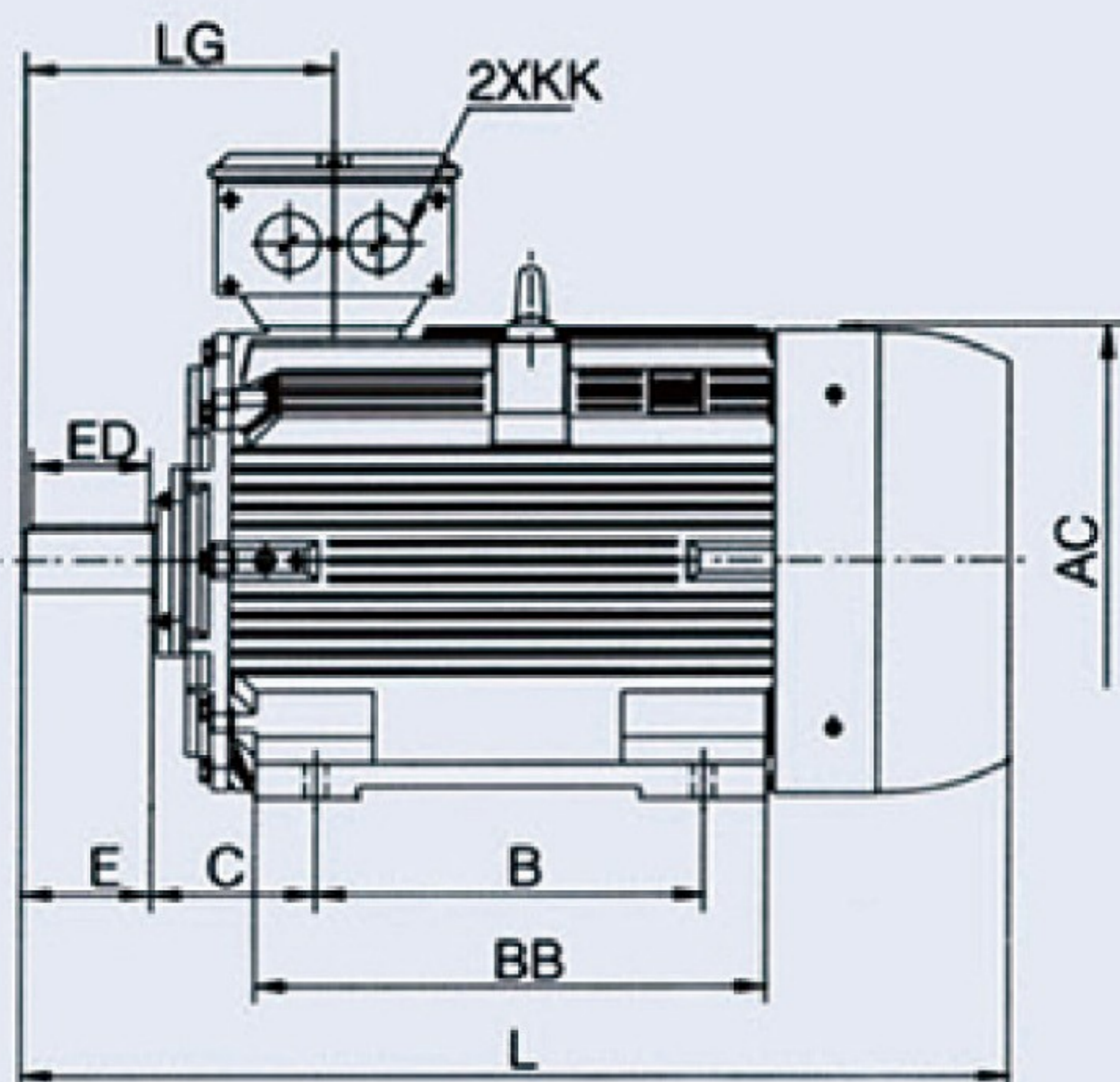

DIMENSIONS MOUNTS B3

Frame	pole	A	AA	AB	AC	B	BB	C	D	DH	E	ED	F	G	GD	KK	H	HA	HD	K	L
80	2-8	125	35	160	160	100	130	50	19	M6X16	40	25	6	15.5	6	M24X15	80	12	225	10	280
90S	2-8	140	36	180	180	100	140	56	24	M8X19	50	40	8	20	7	M24X15	90	12	245	10	315
90L	2-8	140	36	180	180	125	165	56	24	M8X19	50	40	8	20	7	M24X15	90	12	245	10	340
100	2-8	160	40	200	200	140	175	63	28	M10X22	60	45	8	24	7	M24X15	100	14	280	12	375
112	2-8	190	45	230	220	140	180	70	28	M10X22	60	45	8	24	7	M30X2	112	15	305	12	400
132S	2-8	216	55	265	260	140	190	89	38	M12X28	80	63	10	33	8	M30X2	132	18	355	12	465
132M	2-8	216	55	265	260	178	230	89	38	M12X28	80	63	10	33	8	M30X2	132	18	355	12	505
160M	2-8	254	65	315	315	210	260	108	42	M16X36	110	90	12	37	8	M36X2	160	20	425	15	608
160L	2-8	254	65	315	315	254	305	108	42	M16X36	110	90	12	37	8	M36X2	160	20	425	15	652
180M	2-4	279	70	350	360	241	315	121	48	M16X36	110	90	14	42.5	9	M36X2	180	22	460	15	690
180L	4-8	279	70	350	360	279	350	121	48	M16X36	110	90	14	42.5	9	M36X2	180	22	460	15	730
200L	2-8	318	70	390	400	305	370	133	55	M20X42	110	90	16	49	10	M48X2	200	25	510	19	760
225S	4-8	356	75	435	450	286	370	149	60	M20X42	140	110	18	53	11	M48X2	225	28	555	19	810
225M	2	356	75	435	450	311	395	149	55	M20X42	110	90	16	49	10	M48X2	225	28	555	19	805
225M	4-8	356	75	435	450	311	395	149	60	M20X42	140	90	16	53	11	M48X2	225	28	555	19	835
250M	2	406	80	485	485	349	445	168	60	M20X42	140	110	18	53	11	M48X2	250	30	625	24	910
250M	4-8	406	80	485	485	349	445	168	65	M20X42	140	110	18	58	11	M48X2	250	30	625	24	910
280S	2	457	85	545	550	368	490	190	65	M20X42	140	110	18	58	11	M64X2	280	35	685	24	985
280S	4-8	457	85	545	550	368	490	190	75	M20X42	140	110	20	67.5	12	M64X2	280	35	685	24	1005
280M	2	457	85	545	550	419	540	190	65	M20X42	140	110	18	58	11	M64X2	280	35	685	24	1030
280M	4-8	457	85	545	550	419	540	190	75	M20X42	140	110	20	67.5	12	M64X2	280	35	685	24	1060
315S	2	508	120	630	625	406	570	216	65	M20X42	140	110	18	58	11	M64X2	315	45	845	28	1180
315S	4-8	508	120	630	625	406	570	216	80	M20X42	170	140	22	71	14	M64X2	315	45	845	28	1210
315M	2	508	120	630	625	457	680	216	65	M20X42	140	110	18	58	11	M64X2	315	45	845	28	1290
315L	4-8	508	120	630	625	457	680	216	80	M20X42	170	140	22	71	14	M64X2	315	45	845	28	1320
355M	2	610	120	730	700	500	750	254	75	M20X42	140	110	20	67.5	12	M64X2	355	52	970	28	1526
355M	4-8	610	120	730	700	500	750	254	95	M20X42	170	140	25	86	14	M64X2	355	52	970	28	1556
355L	2	610	120	730	700	560	750	254	75	M20X42	140	110	20	67.5	12	M64X2	355	52	970	28	1526
355L	4-8	610	120	730	700	560	750	254	95	M20X42	170	140	25	86	14	M64X2	355	52	970	28	1556

Note: * means that the cable gland is only one.

KK are also available according to the requirement.

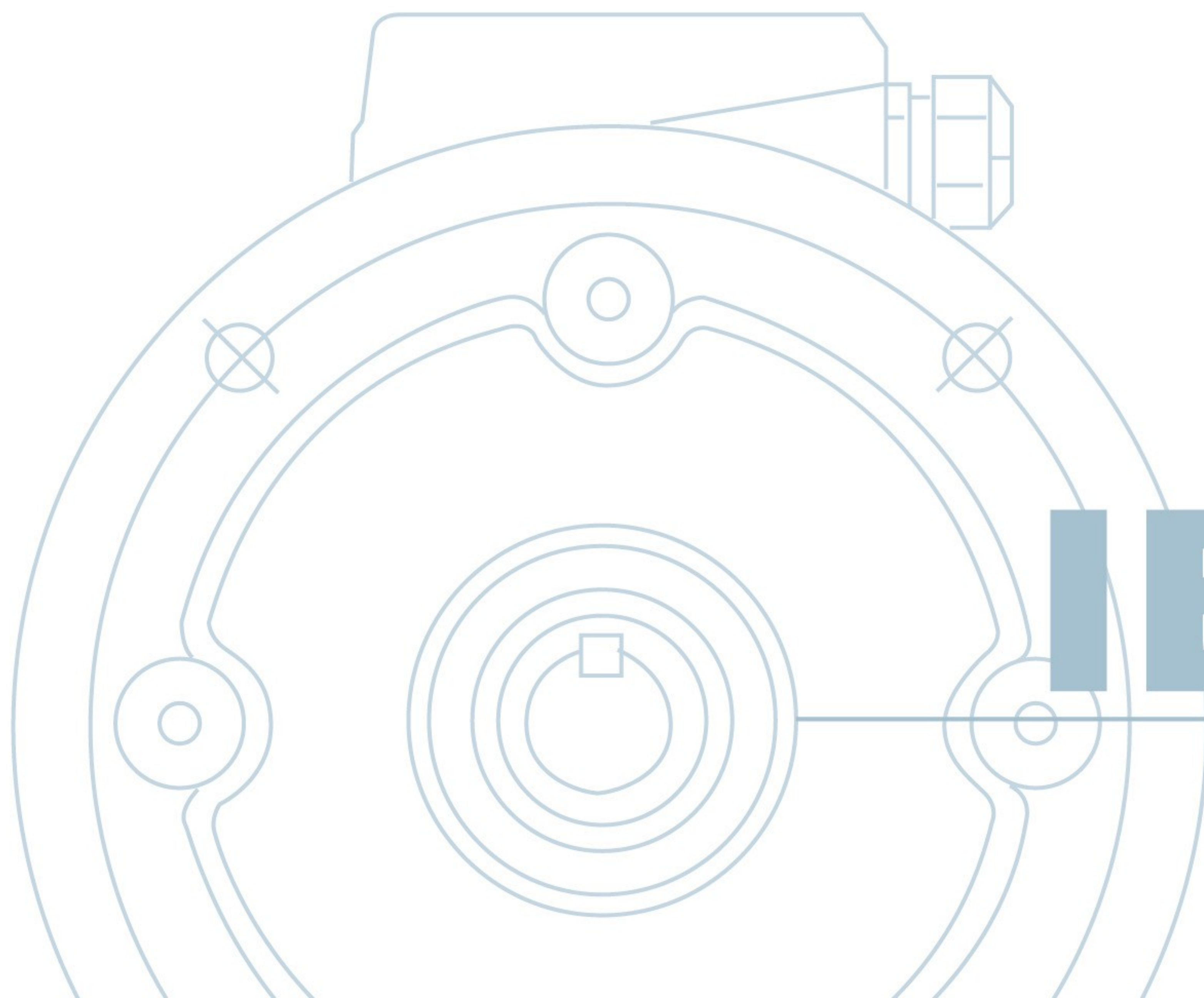

IE2 series

Dimensions flange mount B5 and V1

IE2-56-160

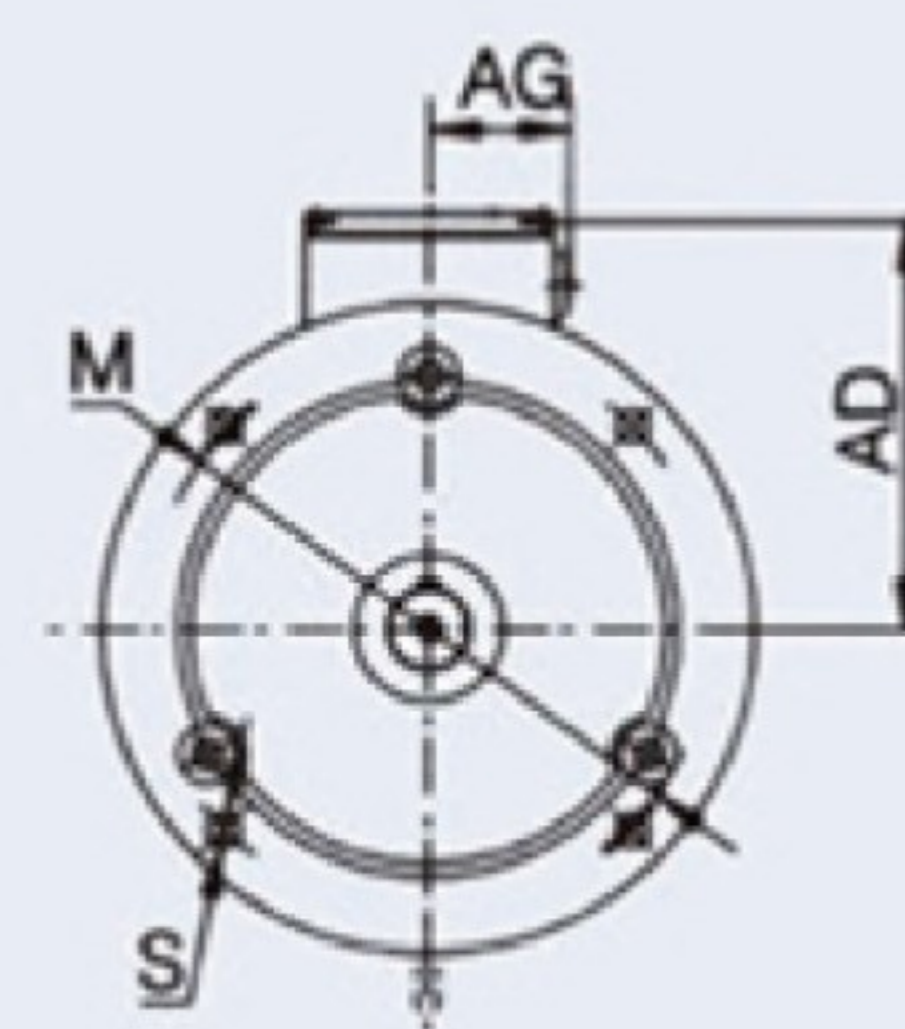
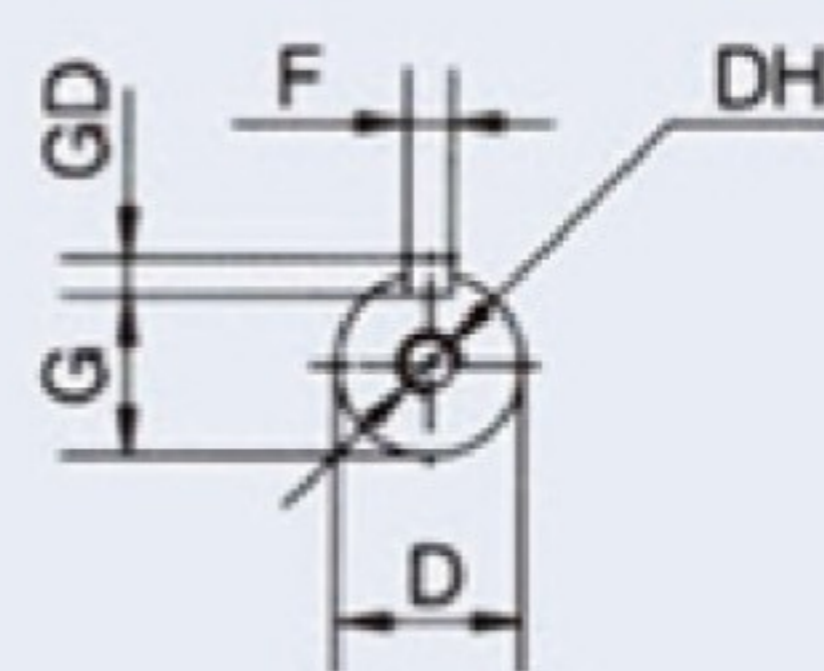
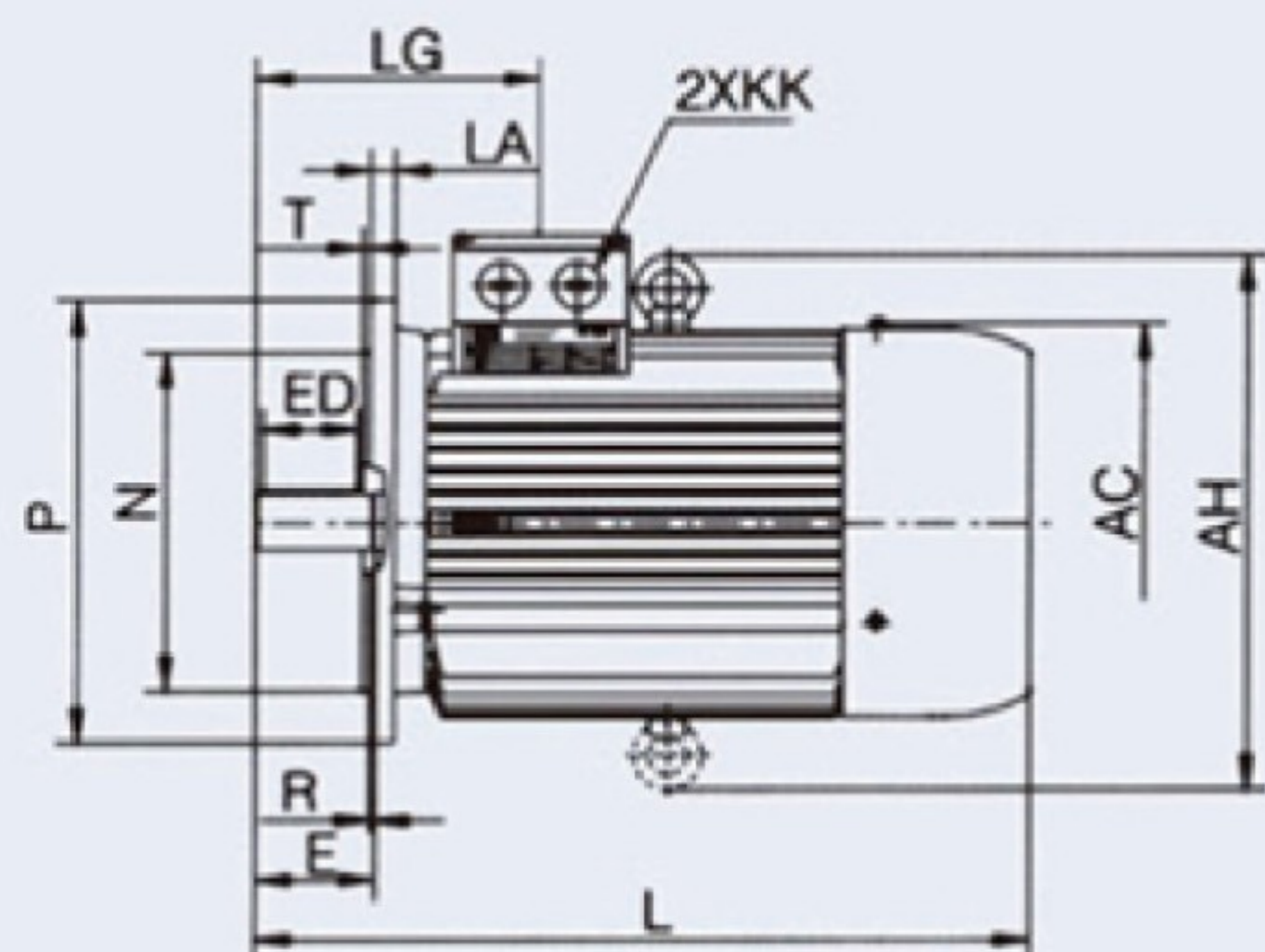

IE2-180-200

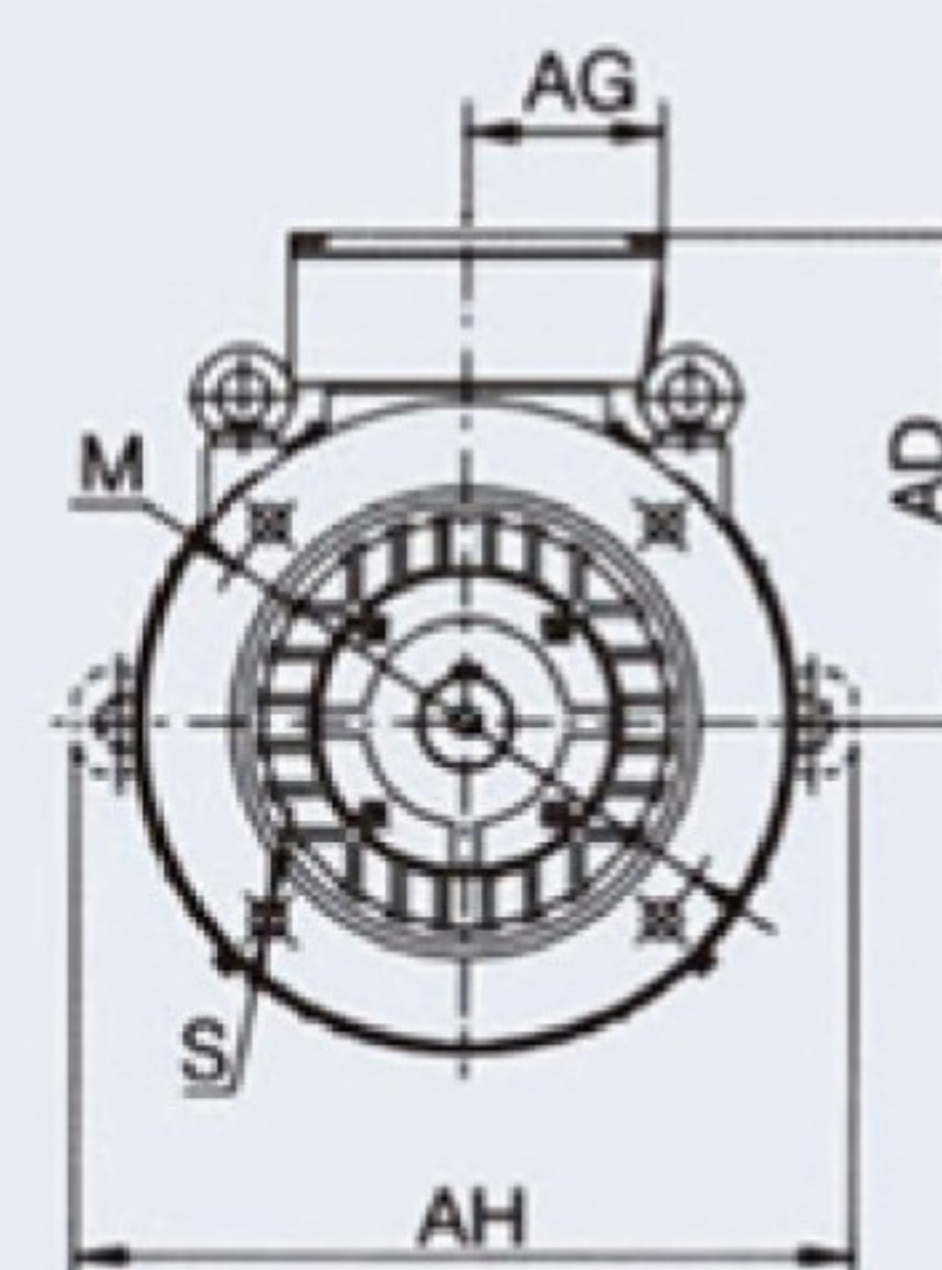
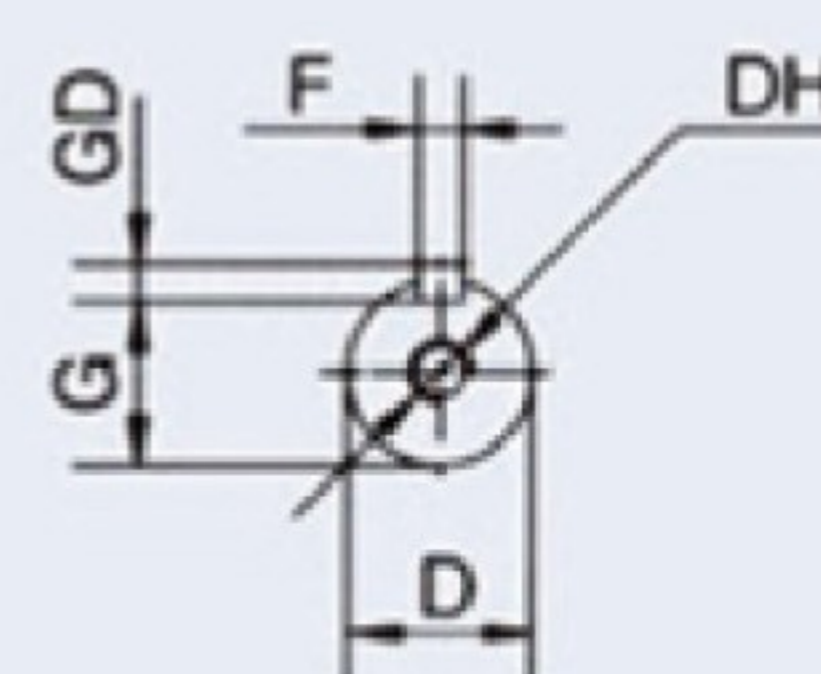
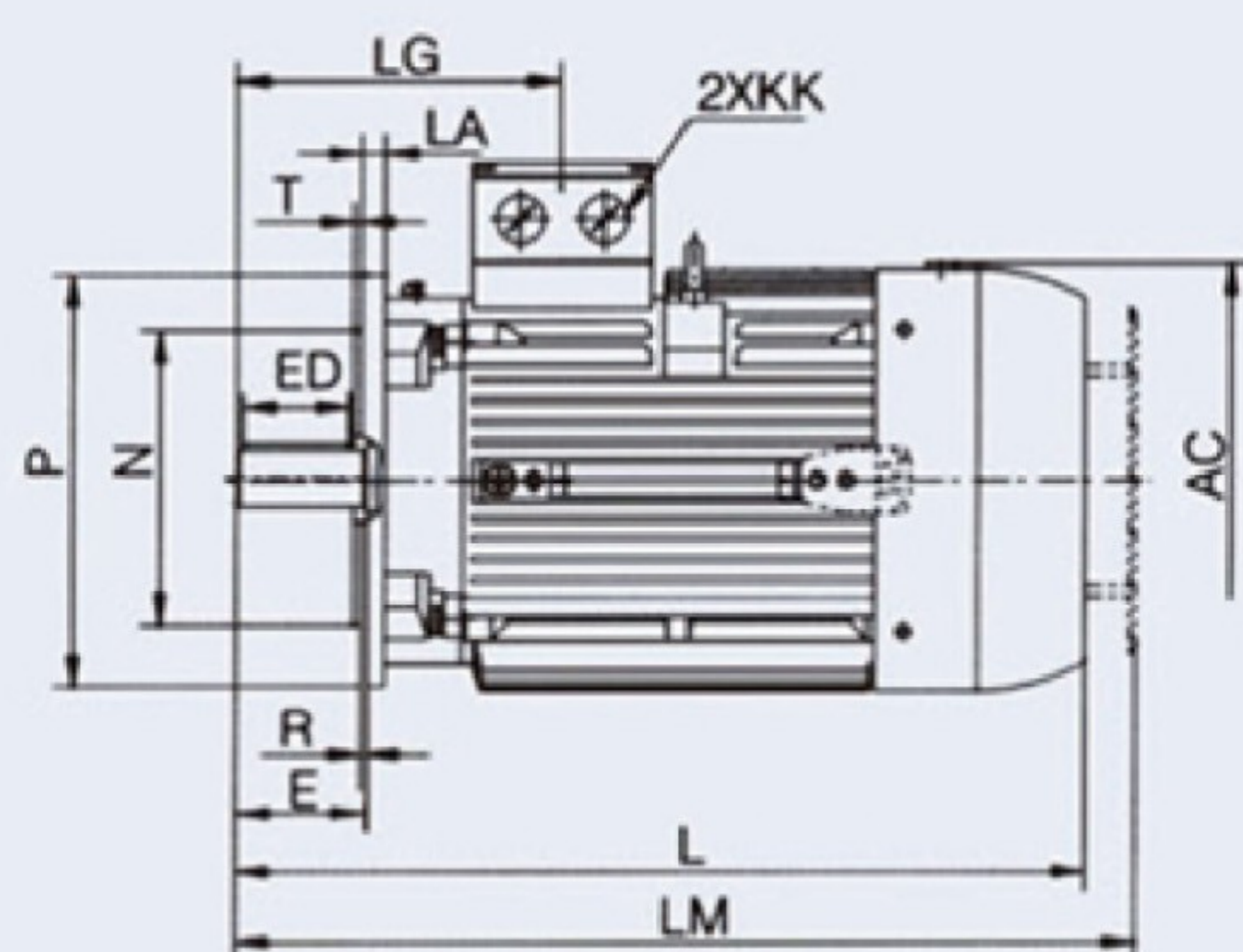

IE2-225-280

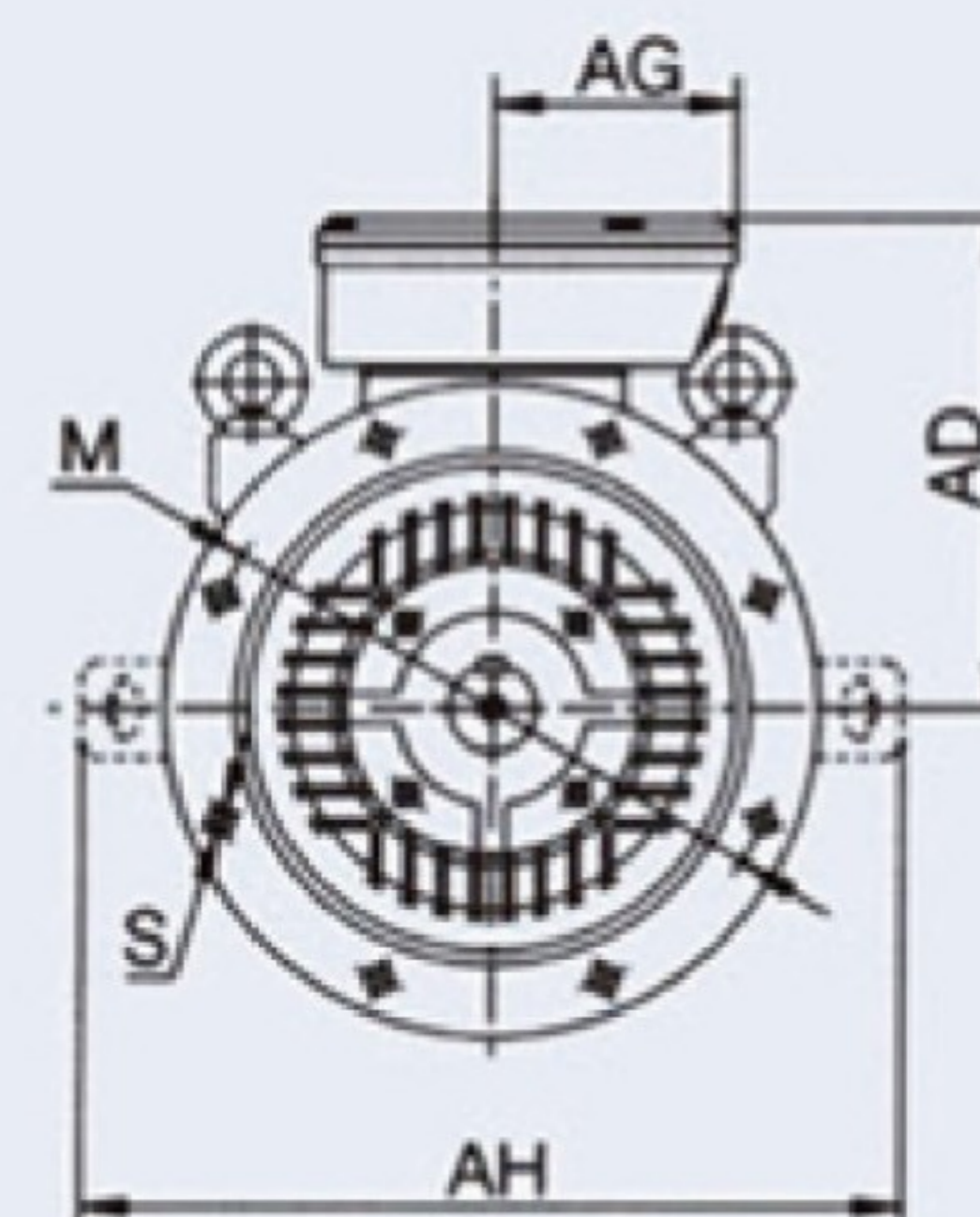
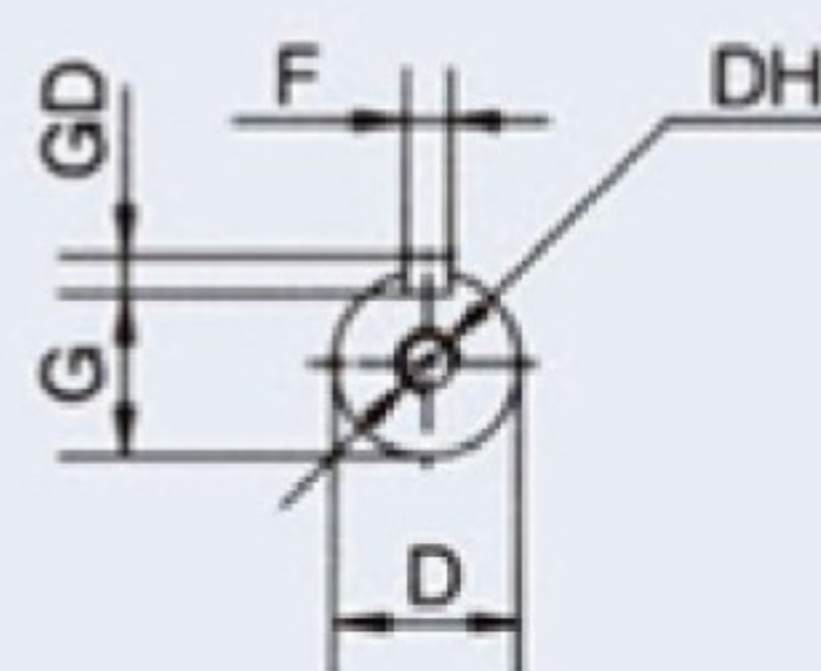
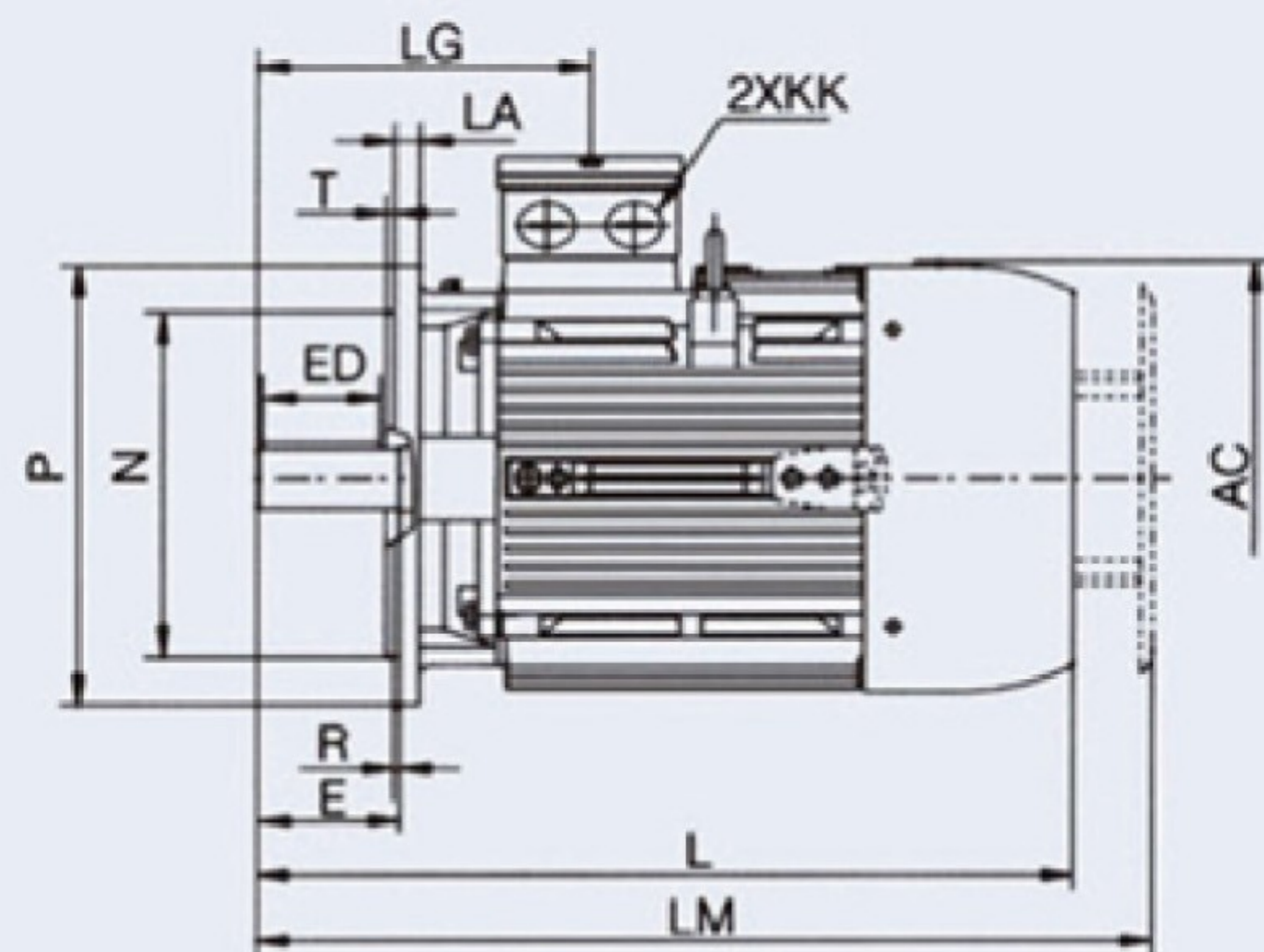

IE2-315-355

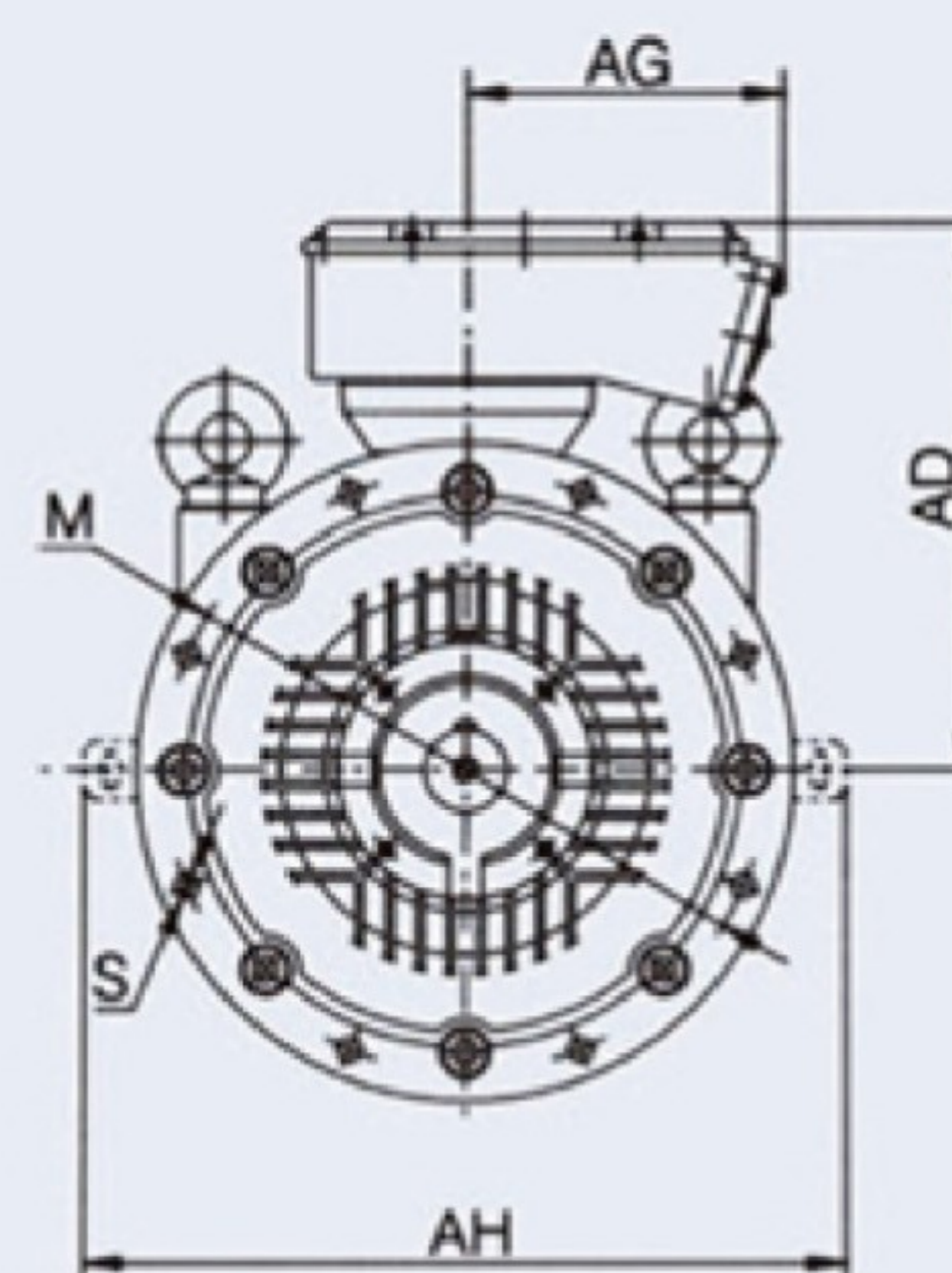
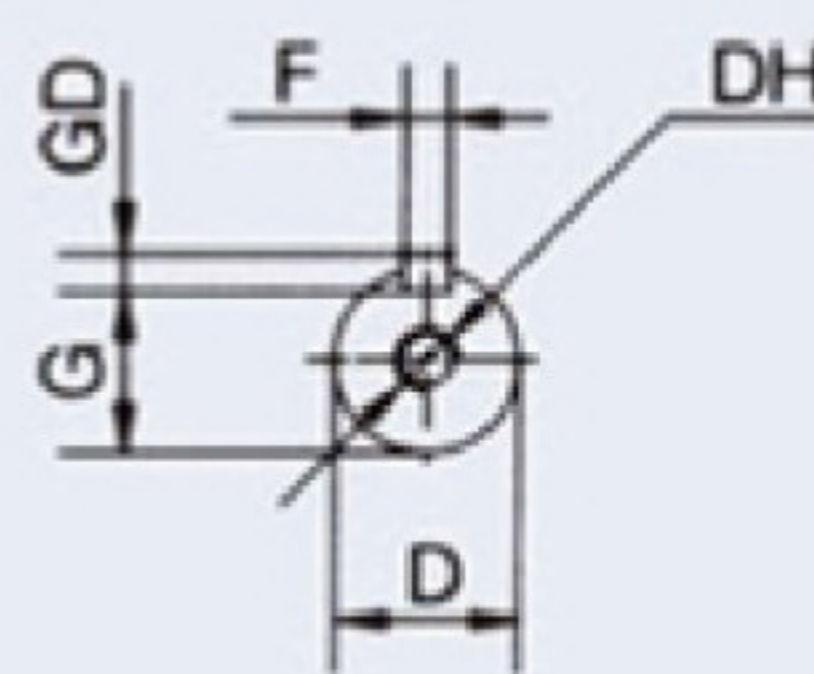
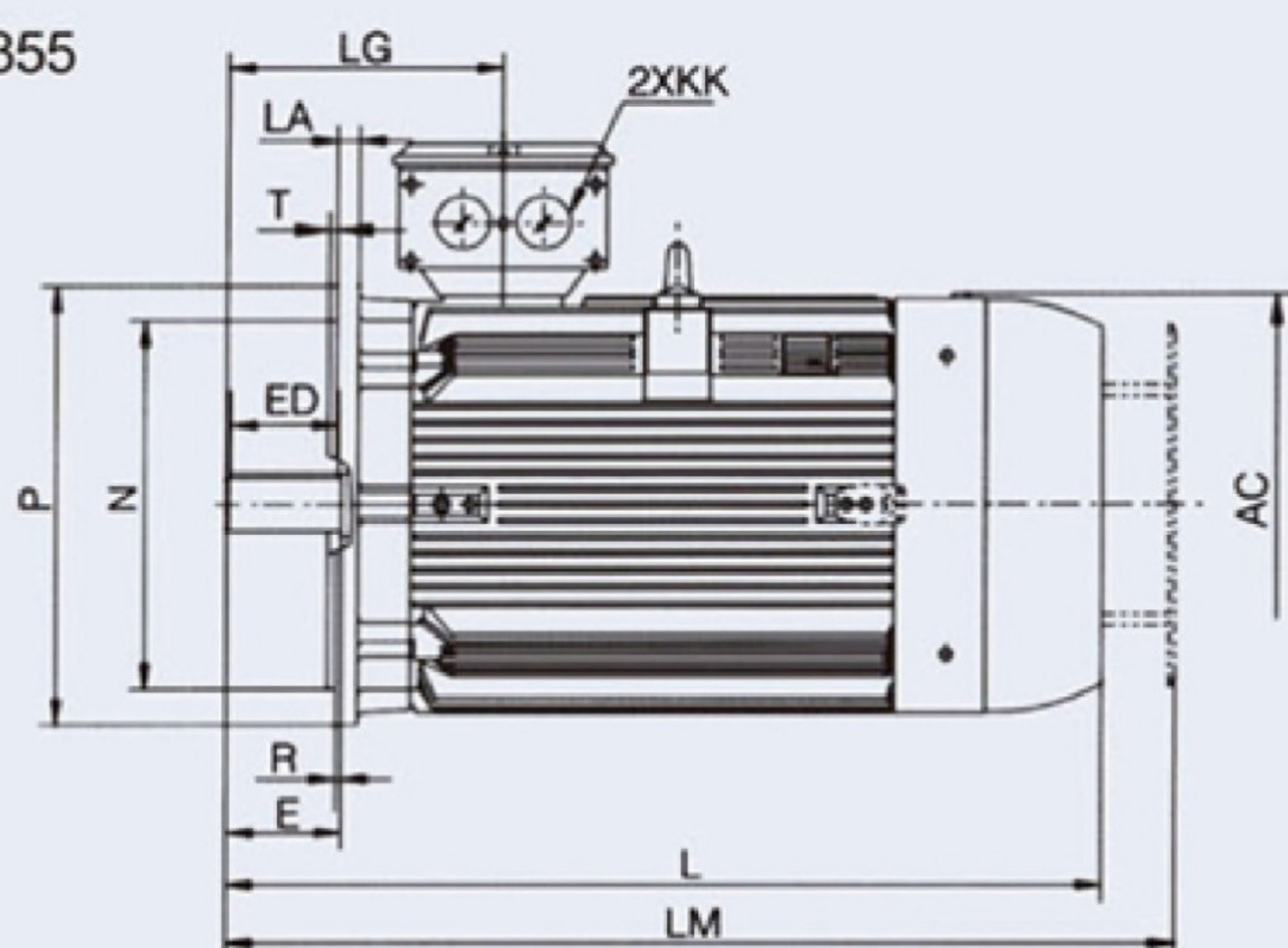



MOTORS

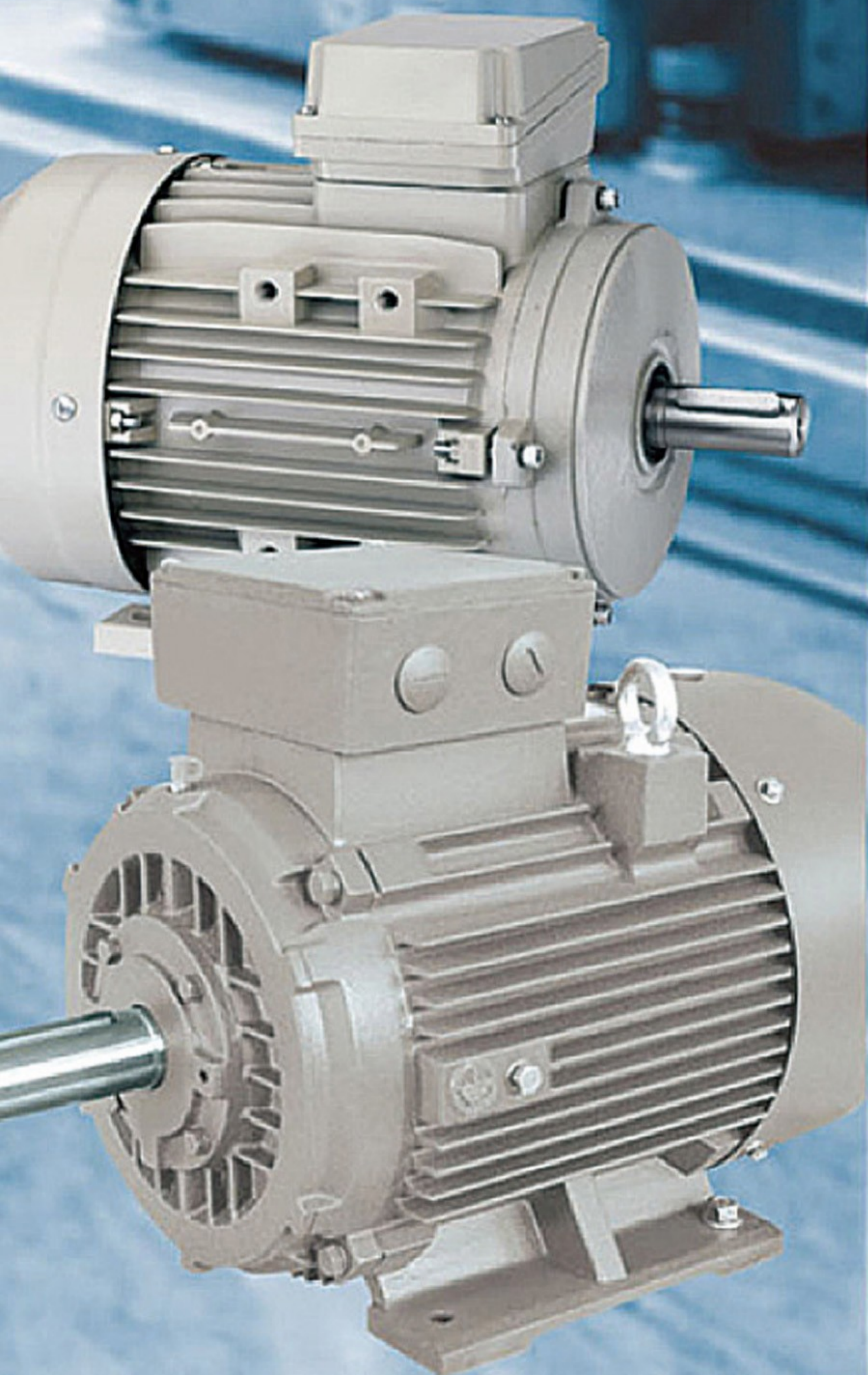

IE2 60Hz

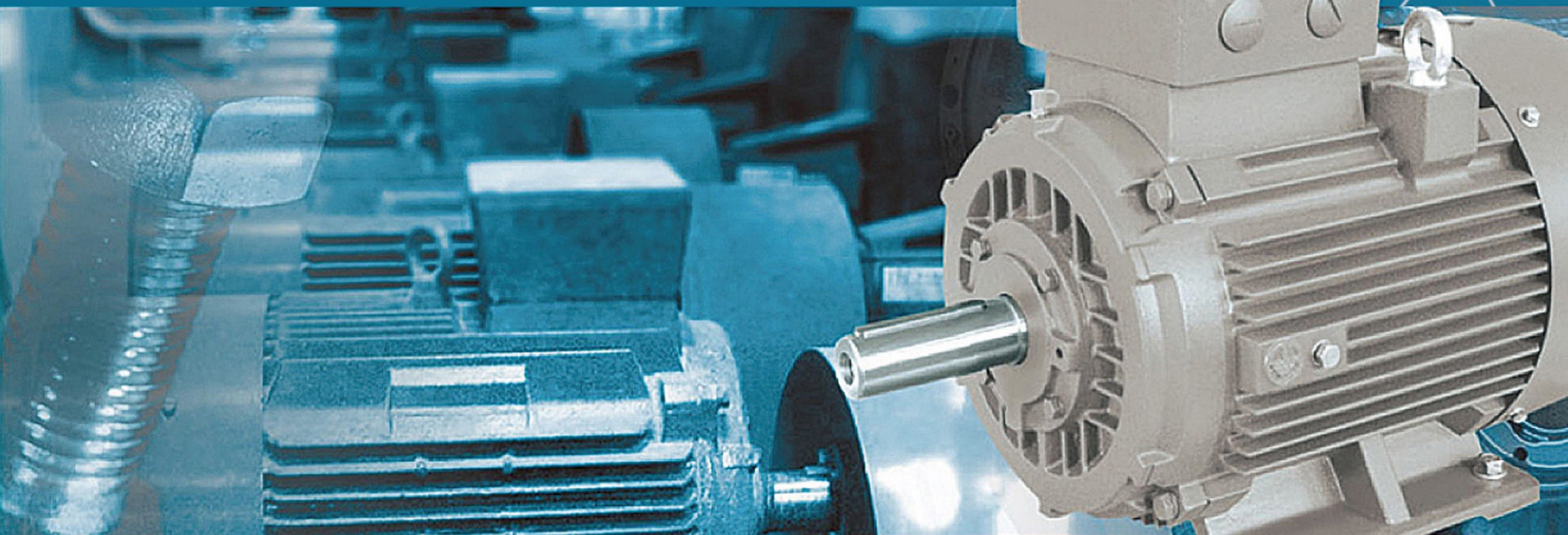

歐規IE2高效率馬達

CE **OMIKSO** MOTORS